

FURUNO

INSTALLATION MANUAL

MARINE RADAR

MODEL FR-2165DS



FURUNO ELECTRIC CO., LTD.
NISHINOMIYA, JAPAN

© **FURUNO ELECTRIC CO., LTD.**

9-52, Ashihara-cho,
Nishinomiya, Japan

Telephone: 0798-65-2111
Telefax: 0798-65-4200

•Your Local Agent/Dealer

All rights reserved. Printed in Japan

FIRST EDITION : NOV 1998
B : JUL. 13, 1999

(DAMI) PUB. No. IME-34680-B
FR-2165DS



* 00080839100 *



SAFETY INSTRUCTIONS

WARNING

Radio Frequency Radiation Hazard

The radar scanner emits electromagnetic radio frequency (RF) energy which can be harmful, particularly to your eyes. Never look directly into the scanner aperture from a close distance while the radar is in operation or expose yourself to the transmitting scanner at a close distance.

Distances at which RF radiation levels of 100 and 10 W/m² exist are given in the table below.

Note: If the scanner unit is installed at a close distance in front of the wheelhouse, your administration may require halt of transmission within a certain sector of scanner revolution. This is possible. Ask your FURUNO representative or dealer to provide this feature.

Model	Radiator type	Distance to 100W/m ² point	Distance to 10W/m ² point
FR-2165DS	SN4A	—	1.2 m
	SN5A	—	1.0 m

WARNING



ELECTRICAL SHOCK HAZARD

Do not open the equipment unless totally familiar with electrical circuits and service manual.

Only qualified personnel should work inside the equipment.



Wear a safety belt and hard hat when working on the scanner unit.

Serious injury or death can result if someone falls from the radar scanner mast.

Construct a suitable service platform from which to install the scanner unit.

Serious injury or death can result if someone falls from the radar scanner mast.

Turn off the power at the mains switchboard before beginning the installation.

Fire, electrical shock or serious injury can result if the power is left on or is applied while the equipment is being installed.

Do not install the display unit where it may get wet from rain or water splash.

Water in the display unit can result in fire, electrical shock or equipment damage.



WARNING

Be sure that the power supply is compatible with the voltage rating of the equipment.

Connection of an incorrect power supply can cause fire or equipment damage. The voltage rating of the equipment appears on the label above the power connector.

Use only the specified power cable.

Fire or equipment damage can result if a different cable is used.



CAUTION



Ground the equipment to prevent electrical shock and mutual interference.

Observe the following compass safe distances to prevent deviation of a magnetic compass:

	Standard compass	Steering compass
Display Unit	1.70 m	0.90 m
Scanner Unit	2.15 m	1.60 m
Power supply unit PSU-004	0.50 m	0.30 m
Power supply unit PSU-001	1.20 m	0.90 m

TABLE OF CONTENTS

EQUIPMENT LISTS	iv
SYSTEM CONFIGURATION	vi

MOUNTING

1.1 Scanner Unit	1-1
1.2 Display Unit	1-7
1.3 Power Supply Units	1-15

WIRING

2.1 Scanner Unit	2-1
2.2 Display Unit	2-5
2.3 Changing AC Power Specification of Display Unit	2-10
2.4 Power Supply Units	2-11
2.5 Installation and Connection of Rectifier Unit	2-13

INITIALIZATION AND ADJUSTMENT

3.1 Tuning Initialization	3-1
3.2 Accessing Menus for Initialization and Adjustment	3-1
3.3 Adjusting Video Signal Level	3-1
3.4 Heading Alignment	3-2
3.5 Adjusting Sweep Timing	3-3
3.6 Suppressing Main Bang	3-3
3.7 Confirming Magnetron Heater Voltage	3-4
3.8 Initial Setting Menus	3-6

INSTALLATION OF OPTIONAL EQUIPMENT

4.1 Gyro Converter GC-8	4-1
4.2 ARP Board ARP-26	4-7
4.3 RP Board RP-26	4-10
4.4 Performance Monitor PM-30	4-14
4.5 Alarm Kit	4-15

PACKING LISTS	A-1
----------------------------	------------

OUTLINE DRAWINGS	D-1
-------------------------------	------------

INTERCONNECTION DIAGRAM	S-1
--------------------------------------	------------

SCHEMATIC DIAGRAMS	S-2
---------------------------------	------------

EQUIPMENT LISTS

Standard Supply

Name	Type	Code No.	Qty	Remarks	
Scanner Unit	SN4A-RSB-0051-N-3	–	Select one	24 rpm, 2500 mm, no deicer	
	SN4A-RSB-0051-I-3	–		24 rpm, 2500 mm, w/deicer	
	SN5A-RSB-0051-N-3	–		24 rpm, 2700 mm, no deicer	
	SN5A-RSB-0051-I-3	–		24 rpm, 2700 mm, w/deicer	
Display Unit	RDP-124	–	1		
Power Supply Unit for Scanner Unit	PSU-001-60	–	Select one	100 VAC	
	PSU-001-61	–		110 VAC	
	PSU-001-62	–		115 VAC	
Power Supply Unit	PSU-004-2-50-S	–	1		
Spare Parts	SP03-12800	000-087-692	1	For DC power	
Installation Materials*	CP03-19900	000-089-393	Select one	CP03-14601, CP03-19103, CP03-13916, CP03-13907, Signal Cable S03-84-15 (15 m)	S E E P A C K I N G L I S T S
	CP03-19910	000-089-394		CP03-14601, CP03-19103, CP03-13916, CP03-13907, Signal Cable S03-84-20 (20 m)	
	CP03-19920	000-089-395		CP03-14601, CP03-19103, CP03-13916, CP03-13907, Signal Cable S03-84-30 (30 m)	
	CP03-19930	000-089-396		CP03-14601, CP03-19103, CP03-13916, CP03-13907, Signal Cable S03-84-60 (60 m)	
Accessories	FP03-06510	000-089-400	1	FP03-06201, FP03-06502, FP03-06503	
	FP03-06550	000-089-476		For console: FP03-06201, FP03-06502, FP03-06503, FP03-06504	

* CP03-14601: For scanner unit, CP03-19103: For display unit, CP03-13916: For power supply unit PSU-004, CP03-13907: For power supply unit PSU-001

Optional Equipment

Name	Type	Code No.	Qty	Remarks
Rectifier	RU-3423	000-030-443	1	AC → 24 VDC
Slave Display	FMD-8010	-	1	
Gyro Converter	GC-8-2	008-446-520	1 set	Separate shipment
Interswitch	RJ-7	-	1	
Interswitch	RJ-8	-	1	
Performance Monitor	PM-50	-	1	
Transformer Unit	RU-1758	000-030-416	1	220 V → 100 V, for display unit
	RU-1803	000-030-420	1	440 V → 100 V, for display unit
	RU-6522	000-030-410	1	220 V → 200 V, for scanner unit
	RU-3305	000-030-448	1	For deicer
PM Installation Kit	OP03-150	008-485-490	1 set	
ARPA	ARP-26	008-485-500	1 set	
Video Plotter	RP-26-T	008-485-510	1 set	For tabletop, console type display unit
	RP-26-Z	008-485-520		For separate type control head
Separate Control Head Mounting Kit	OP03-151	008-485-530	1	
Alarm Kit	OP03-156	008-500-650	1	

SYSTEM CONFIGURATION

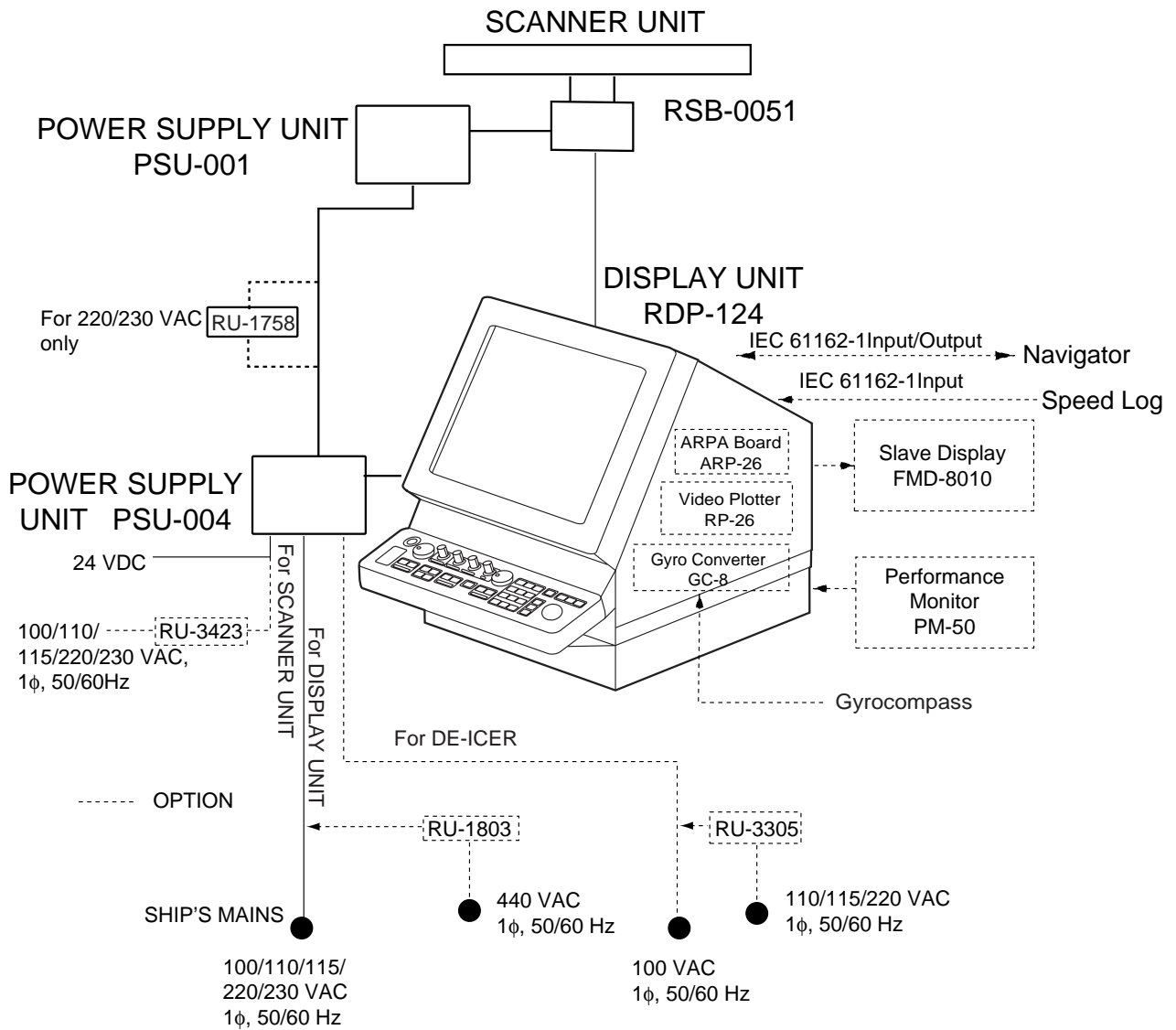

MOUNTING

1.1 Scanner Unit

Mounting considerations

- The scanner unit is generally installed either on top of the wheelhouse or on the radar mast, on a suitable platform. Locate the scanner unit where there is a good all-round view.
- No funnel, mast or derrick should be within the vertical beamwidth of the scanner in the bow direction, especially zero degrees $\pm 5^\circ$, to prevent blind sectors and false echoes on the radar picture.
- It is rarely possible to place the scanner unit where a completely clear view in all directions is available. Thus, you should determine the angular width and relative bearing of any shadow sectors for their influence on the radar at the first opportunity after fitting.
- Locate the antenna of a direction finder clear of the scanner unit to prevent interference to the direction finder. A separation of more than two meters is recommended.
- To lessen the chance of picking up electrical interference, avoid where possible routing the signal cable near other onboard electrical equipment. Also avoid running the cable in parallel with power cables.
- A magnetic compass will be affected if placed too close to the scanner unit. Observe the following compass safe distances to prevent deviation of a magnetic compass: Standard compass, 2.15 m, Steering compass, 1.60 m.
- Do not paint the radiator aperture, to ensure proper emission of the radar waves.
- The signal cable run between the scanner and the display is available in lengths of 15 m (standard), 20 m, 30 m and 60 m. Whatever length is used it must be unbroken; namely, no splicing allowed.
- Deposits and fumes from a funnel or other exhaust vent can adversely affect the aerial performance and hot gases may distort the radiator portion. The scanner unit must not be mounted where the temperature is more than 70°C.
- The scanner base is made of cast aluminum. To prevent electrolytic corrosion of the scanner base, use the seal washers and corrosion-proof rubber mat and ground the unit with the ground wire (supplied).
- Leave sufficient space around the unit for maintenance and servicing. See the scanner unit outline drawing for recommended maintenance space.

Installation precaution for S-band scanner unit

If an S-band scanner unit is mounted near the end of a platform to provide sufficient rotation clearance for the radiator, the scanner unit, because of its weight, swings up and down by ship's vibration and rolling, exerting excessive levels of stress at the base of the radiator, which can damage the radiator. To prevent this, relocate the scanner unit, or if relocation is not possible, reinforce the platform.

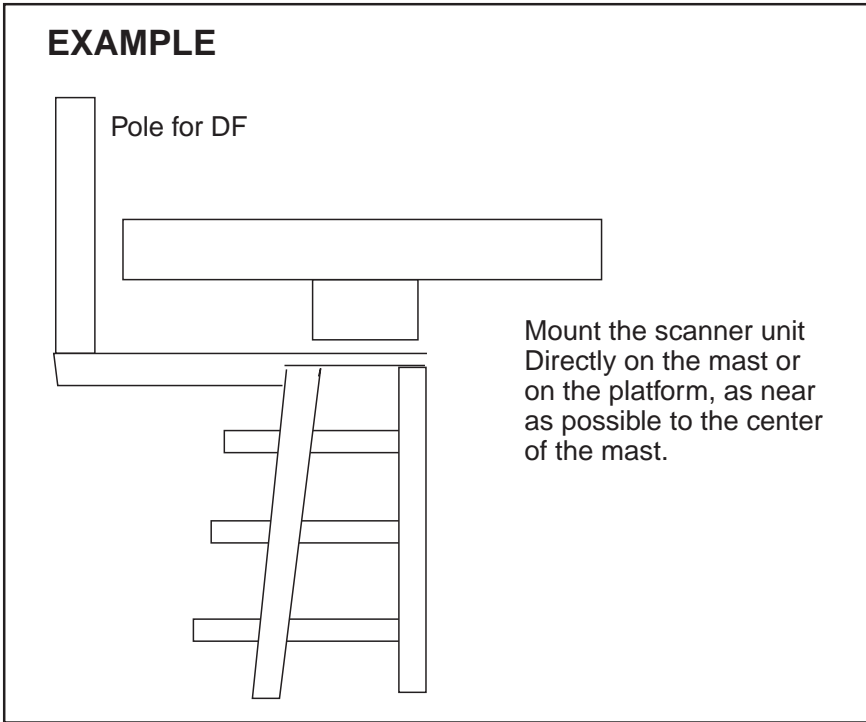
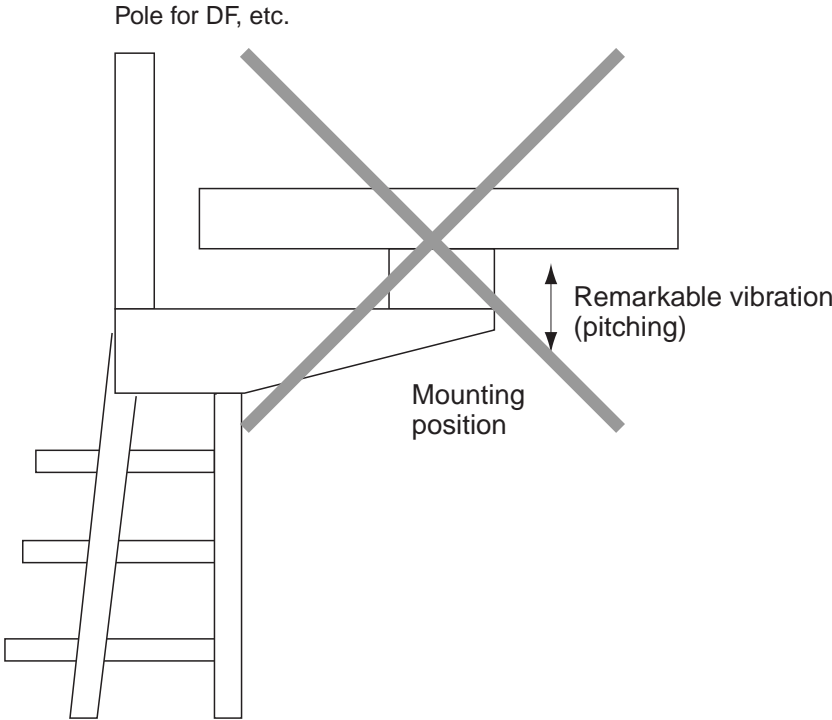

Figure 1-1 Mounting of S-band scanner unit

Scanner unit assembling

The scanner radiator and the scanner housing are shipped in separate packages and must be assembled at installation. Assemble them as below.

The scanner unit may be assembled before hoisting it to the mounting platform. However, do not lift the scanner unit by the radiator.

1. Remove two protective caps from the radiator flange and rotary joint flange.
2. Grease an O-ring and place it in the groove of the rotary joint flange. Make sure the O-ring is not pinched during assembling.
3. Secure the feeder waveguide to the rotary joint flange with four M6x16 hex bolts.
4. Fix the feeder waveguide on the radiator bracket with a waveguide clamp, a clamp insulator, two flat washers, and two M6x50 hex bolts.
5. Grease other O-ring and set it in the groove of the radiator flange.
6. Set the scanner radiator to the bracket and fix it temporarily with eight M10x20 hex bolts, spring washers and flat washers.
7. Fasten the feeder waveguide to the radiator flange with four M6x16 hex bolts.
8. Fasten the scanner radiator to the bracket with eight M10x20 bolts.

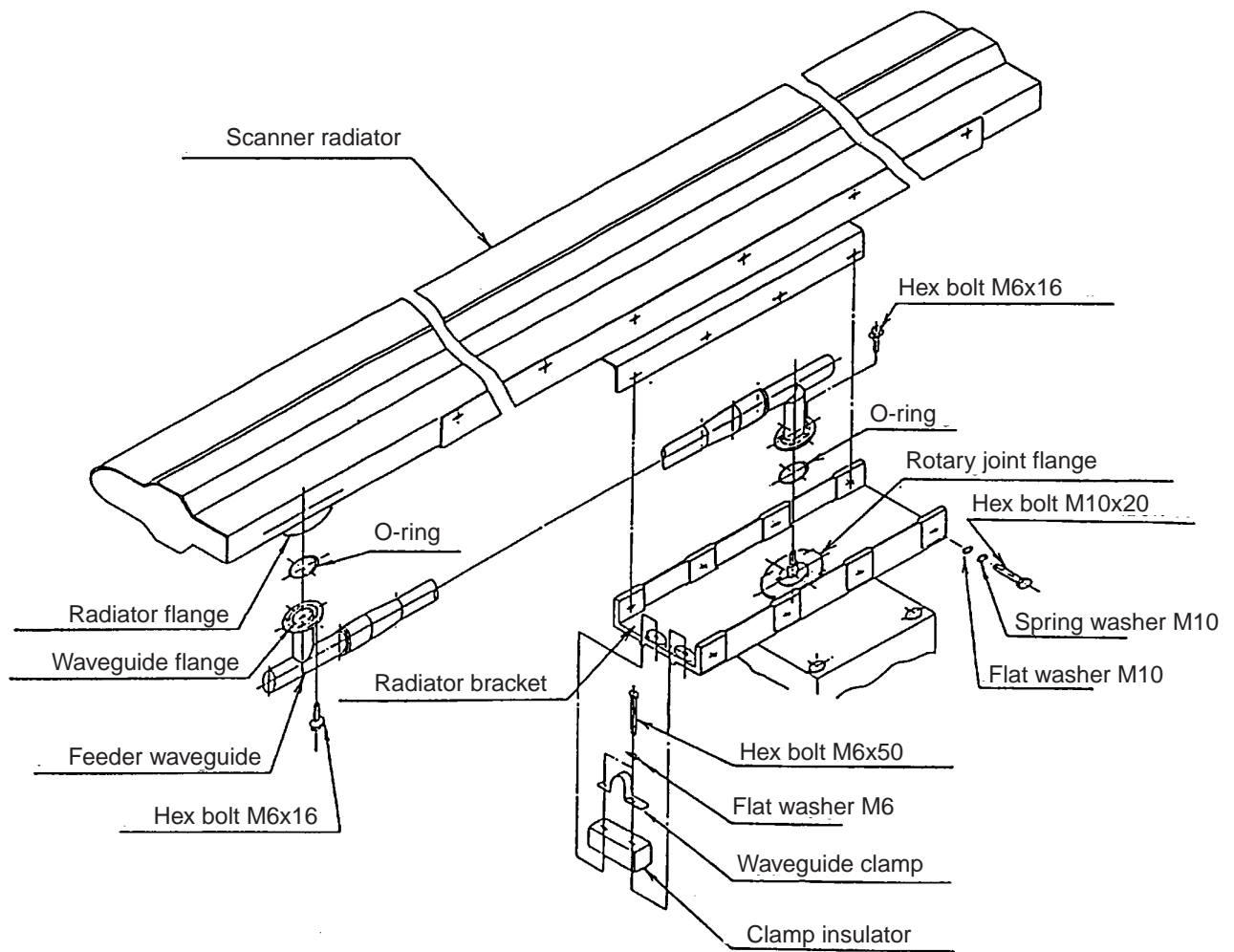

Note 1: Coat bolts, nuts, washers and waveguide flanges outside O-ring grooves to prevent electrolytic corrosion. (Do not allow silicone sealant to touch O-ring and O-ring grooves.)

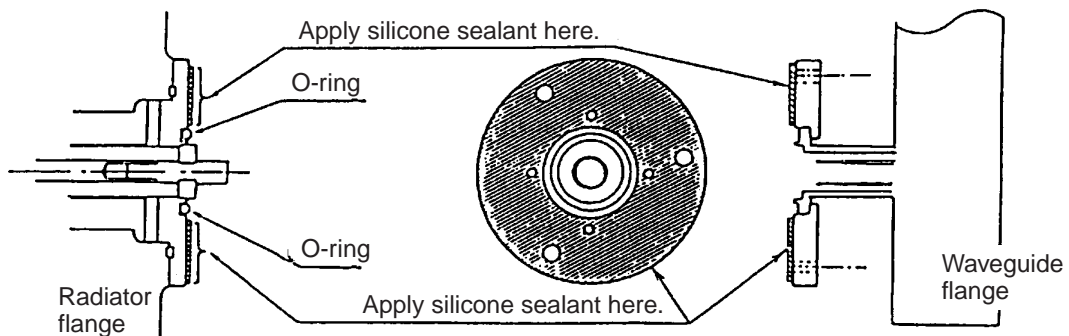

Note 2: Do not pinch O-ring and keep it clean.

Note 3: Use grease on scanner covers and O-rings. Do not use silicone sealant.

Figure 1-2 Scanner unit assembling

Mounting the scanner unit

1. Referring to the scanner outline drawing, drill four bolt holes (15 mm dia.) in the radar mast platform or the deck.
2. Place the corrosion-proof rubber mat (supplied) on the mounting platform.
3. Using the two L-angle metal plates on the scanner top, lift the scanner base with the antenna radiator and place the scanner unit on the rubber mat. Orient the scanner so its cable glands face the ship's stern.

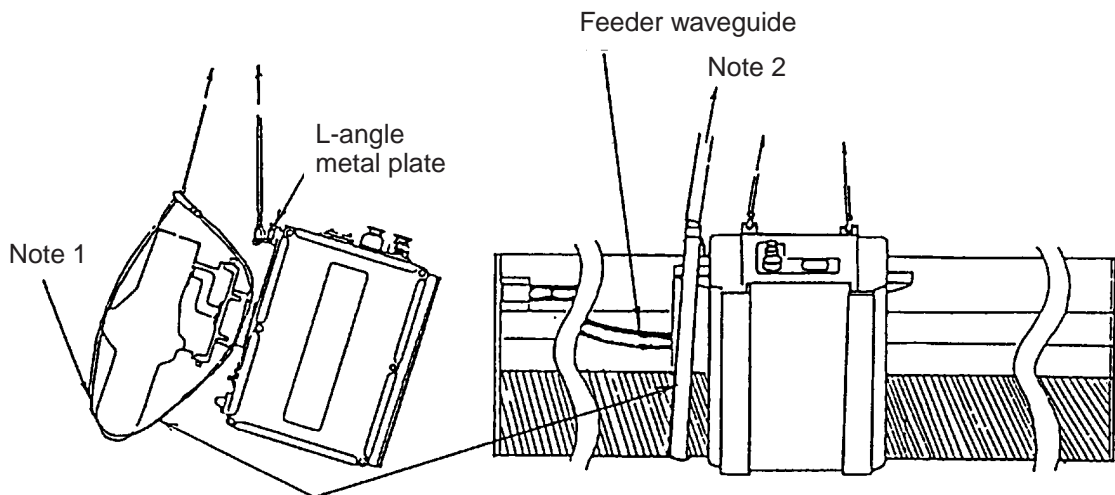

Place the rope around scanner radiator (feeder waveguide side) to prevent scanner from rotating when lifting the scanner base.

Note 1: Take care not to damage scanner exterior by the rope.

Note 2: Tensile load should not be applied to scanner radiator.

Figure 1-3 How to lift the scanner unit

4. Fix the scanner base to the mounting platform with four M12x60 hex bolts, nuts, washers and seal washers (supplied).
5. Arrange the grounding terminal at the nearest grounding spot with the M6x25 hex bolt, nut and washers (supplied). Then, fix a ground wire (RW-4747, 320 mm long) to the terminal.
6. Connect the other end of the ground wire to the ground terminal of the scanner unit.
7. Coat grounding terminal and fixing bolts on the scanner unit with silicone sealant (supplied).

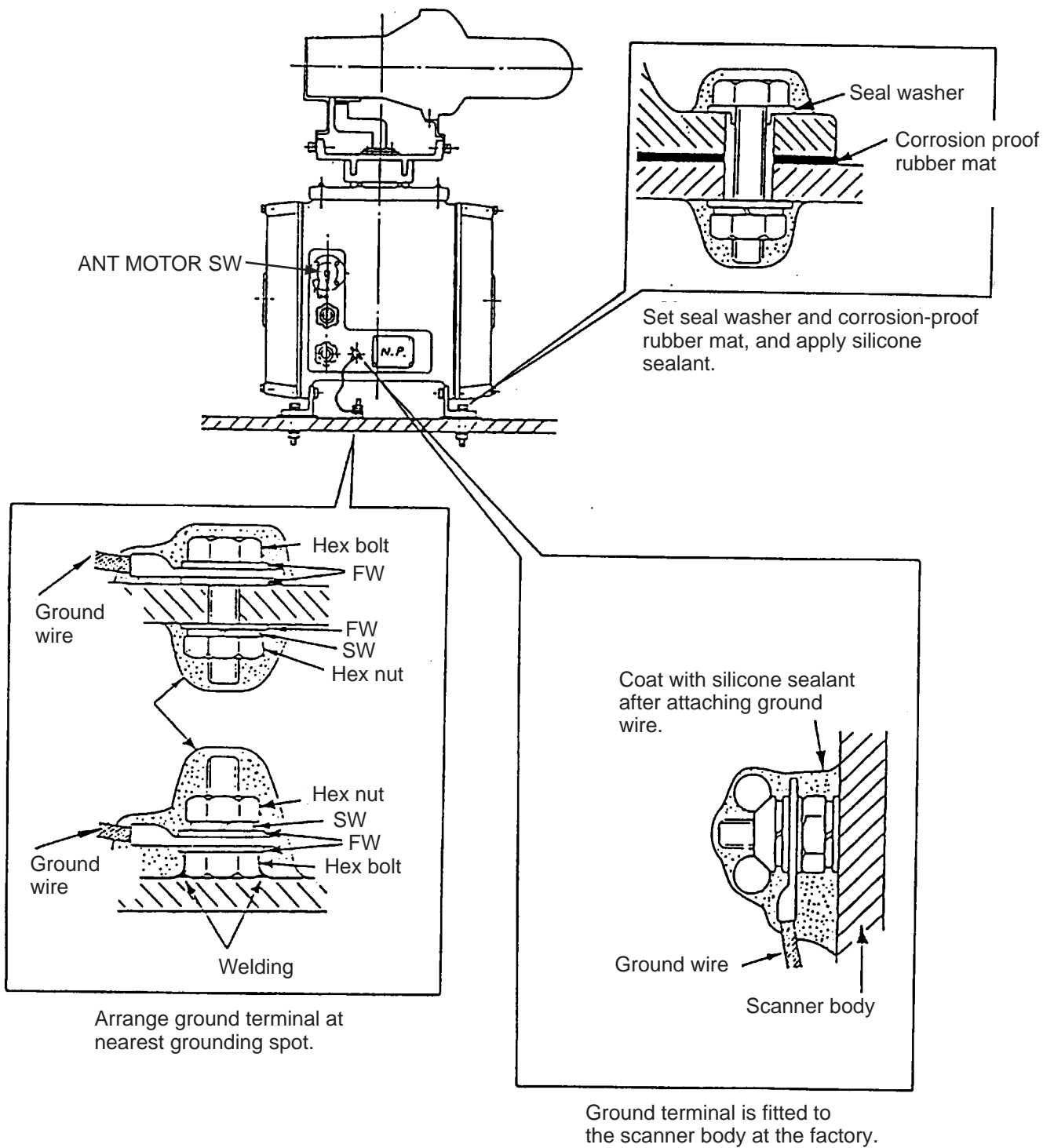

Figure 1-4 Mounting of scanner unit

1.2 Display Unit

Before mounting the display unit

If Gyro Converter GC-8 (option) is to be used, install and setup the GYRO CONVERTER Board before mounting the display unit, because of the difficulty involved in doing it after the display unit is installed. Instructions for installation and setup are in Chapter 4.

Mounting considerations

When selecting a mounting location, keep in mind the following points:

- Select a location where the display unit can be viewed and operated conveniently and where the screen can be viewed while facing towards the bow.
- Locate the unit out of direct sunlight and away from heat sources because of heat that can build up inside the cabinet.
- Locate the equipment away from places subject to water splash and rain.
- The display unit is very heavy. Be sure the mounting location is strong enough to support the weight of the unit under the continued vibration which is normally experienced on the ship. If necessary reinforce the mounting location.
- Determine the mounting location considering the length of the signal cable between the scanner unit and the display unit and the power supply cable between the display unit and the Power Supply Unit PSU-004.
- Leave sufficient space on the sides and rear of the unit to facilitate maintenance. Also, leave a foot or so of “service loop” in cables behind the unit so it can be pulled forward for servicing or easy removal of connectors.
- A magnetic compass will be affected if placed too close to the display unit. Observe the following compass safe distances to prevent deviation of a magnetic compass: Standard compass, 1.70 m, Steering compass, 0.90 m.

Mounting procedure

Tabletop mounting

This procedure requires two people to complete.

1. Make four holes of 12 mm diameter in the mounting location referring to the outline drawing at the end of this manual.
2. Unfasten the screws fixing the right and left brackets on the control panel.
3. Unfasten bolts (four total) in the brackets.

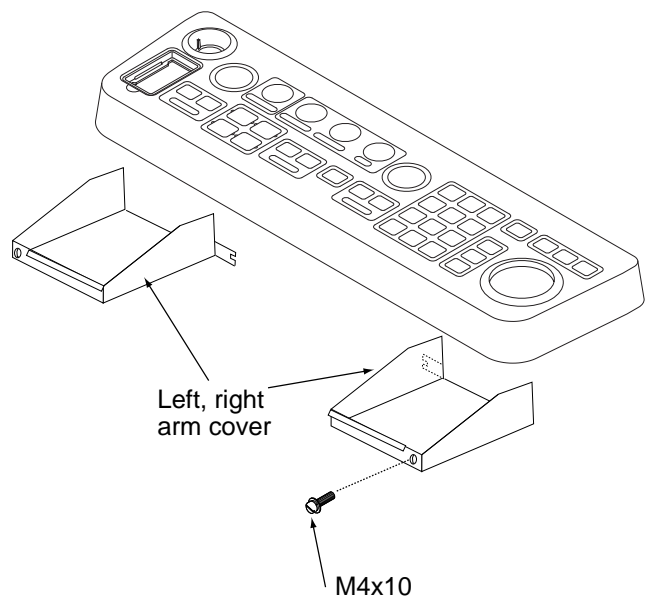

Figure 1-5 Control head

4. While one person is holding the mounting base at the sides, pull the handle on the underside of the control head to draw the display unit toward you until you hear a click.

 CAUTION
<p>Use two people to complete this step.</p> <p>The display unit may fall to the deck when it is pulled forward, since the mounting base is not yet fastened to the mounting location.</p>

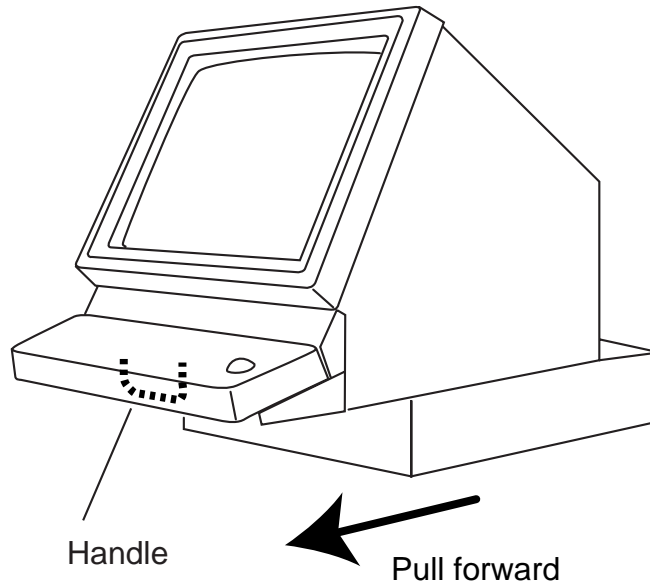

Figure 1-6 Display unit

5. This step requires two people to complete. While raising the monitor until the CRT is horizontal, fix the stay as follows:
 - a) Raise the stay as shown below.

Two warning labels on the underside of monitor





 WARNING	 <p>HORIZONTAL</p> <p>Stay</p>
 <p>Possibility of injury. Hold handle when mounting display unit.</p>	
 WARNING	
 <p>Display unit may fall. Lock stay before servicing.</p>	

Figure 1-7 Display unit, inside view

b) While pushing the stopper, set the catch on the display unit in the hole at the front edge of the stay.

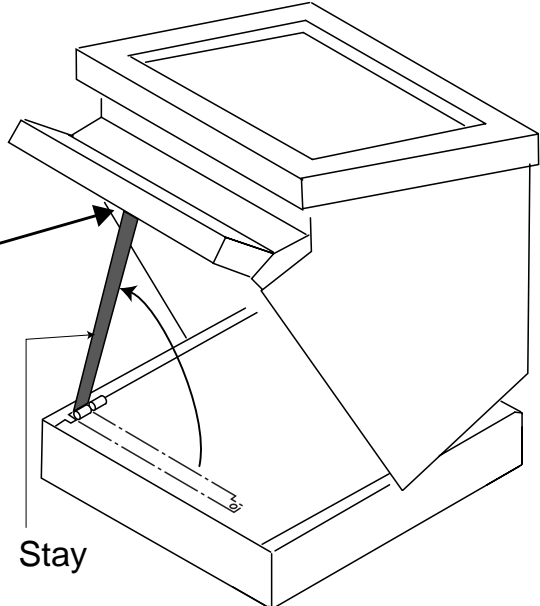
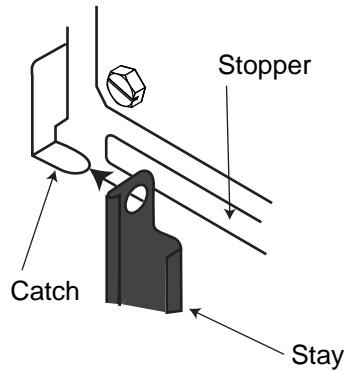

Figure 1-8 Setting catch to hole in stay

c) Release hand from stopper.

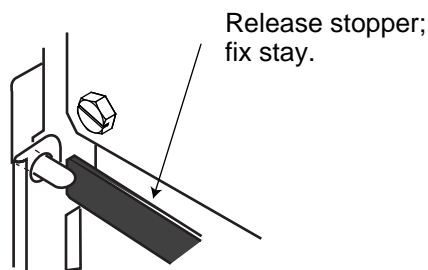

Figure 1-9 Stay fixed

6. Fasten the display unit to the mounting location at front fixing holes (2 points) with M10 bolts, nuts and flat washers, using the pipe box spanner (supplied).

You cannot fasten the display unit at the rear fixing holes while the monitor is raised.

7. Retract the stay and lower the monitor.

8. Fasten the display unit to the mounting locations at rear fixing holes (2 points) with M10 bolts, nuts and flat washers, using the pipe box spanner (supplied).

The rear left hole is hid under the PTU cover. Remove the cover as follows:

- (1) Unfasten five M3x8 screws at the top of the PTU cover and two M4x8 screws at the front of the cover to slide the cover toward the front side.
- (2) Remove the cover by grasping the knob on the top of the cover.

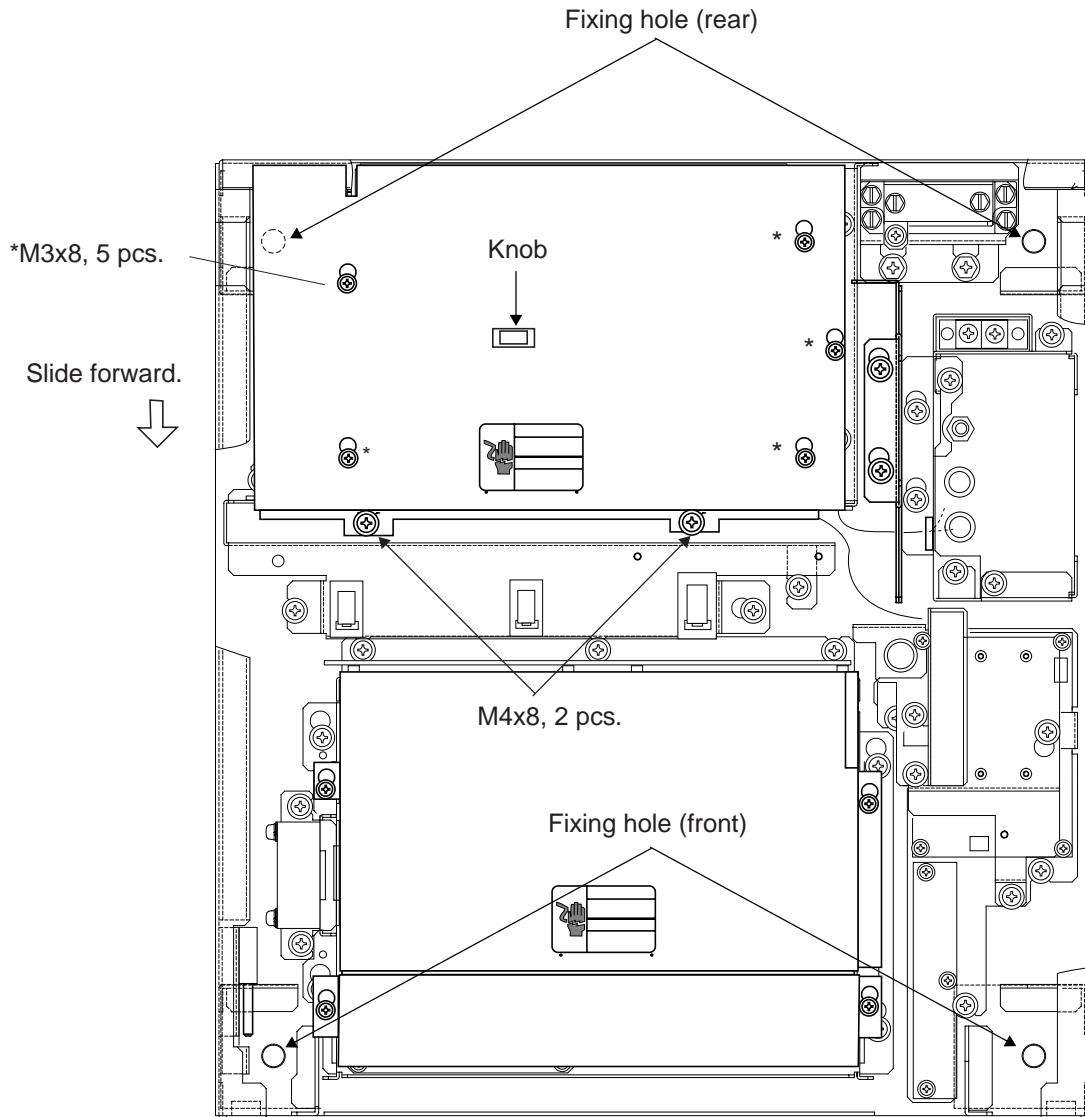

Figure 1-10 How to remove the PTU cover

9. Push the monitor forward until you hear a click.
10. Fix the brackets with the M10 bolts removed at step 3.

Console type mounting

1. Make six holes of 15 mm diameter and a cable entrance hole through the deck referring to the outline drawing at end of this manual.
2. Open the front cover.
3. Fix the equipment with M12 bolts, nuts and washers.
4. Hoist the console to the deck by using the eye bolts attached to the console. Remove the eye bolts and set the cosmetic caps to the eye bolt holes.

Separating the control head

The control head connects to the display unit with a connection cable, thus it can be located where desired, using the separate control head kit (option). Follow the procedure on the next page to separate the control head from the display unit.

Separate type control head kit (Type: OP03-151, No.: 008-485-530)

Name	Type	Qty	Code No.	Remarks
Cable Assy.	UL246SB20P/1P	1	000-140-812	10 m, 03S9422
Nonslip Rubber Feet	A-1042-C-4505	4	000-800-986	w/tape
Monitor Front Cover	03-144-1361	1	100-263-340	
KB Fixing Plate	03-144-1691	1	100-263-940	
Handle Plate	03-144-1632	1	100-268-040	

Display unit modification procedure

1. Raise the monitor unit referring to procedure for tabletop mounting on page 1-7.
2. Unplug two connectors from the control head cable (P412 from MOTHER Board and J583) and unfasten two earth wires.

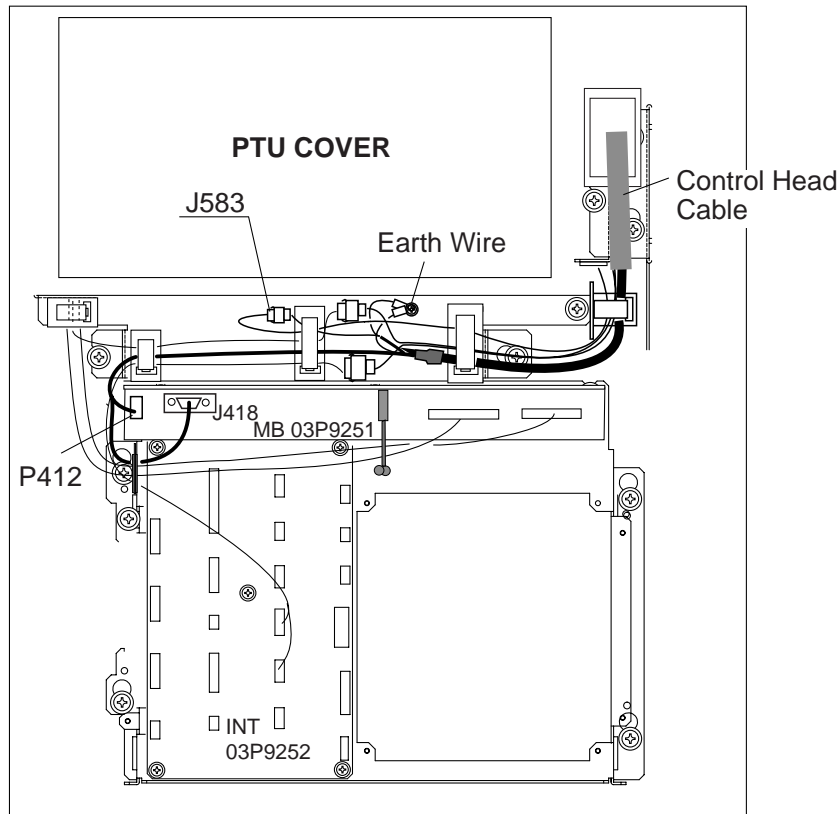

Figure 1-11 Display unit, inside view

3. Lower the monitor.
4. Unfasten the M4 screw fixing the ground terminal of the connection cable.
5. Push the monitor forward until you hear a click.
6. Unscrew four screws fixing the top cover of the display unit.

7. Remove three clamps fixing the connection cable in the monitor unit.
8. Unfasten four screws fixing the right and left brackets on the control head.
9. Unfasten four screws fixing the right and left covers of the display unit.
10. Unfasten six screws fixing the right and left KB arms.
11. Unfasten three screws fixing the panel cover.

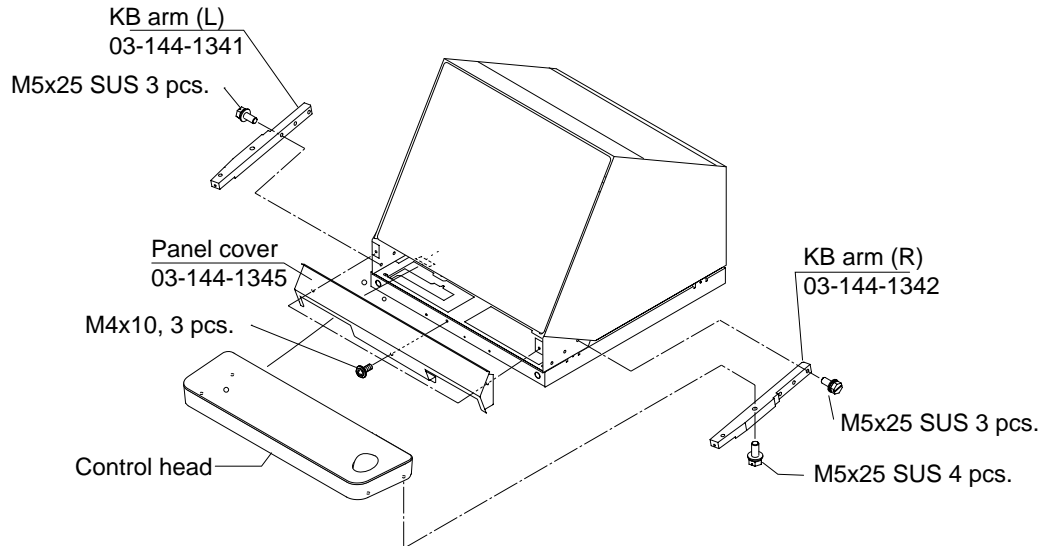

Figure 1-12 Detaching the control head

Control head modification procedure

1. Unfasten eight screws (M4X8) on the underside of the control head. Unplug connectors P314, P312 and P317 from the control head. Separate the KB bottom plate from the control head.
2. Unfasten the screw (M4) fixing the ground terminal and two screws (M4X8) fixing the clamp. Remove the connection cable assy.
3. Unfasten two screws (M6X12) from the inside of the bottom plate of the control head to dismount the handle.

4. Replace the cable assy. with cable assy. UL2464SB2-0P/1P (10 m, supplied) as below and reassemble the control head.

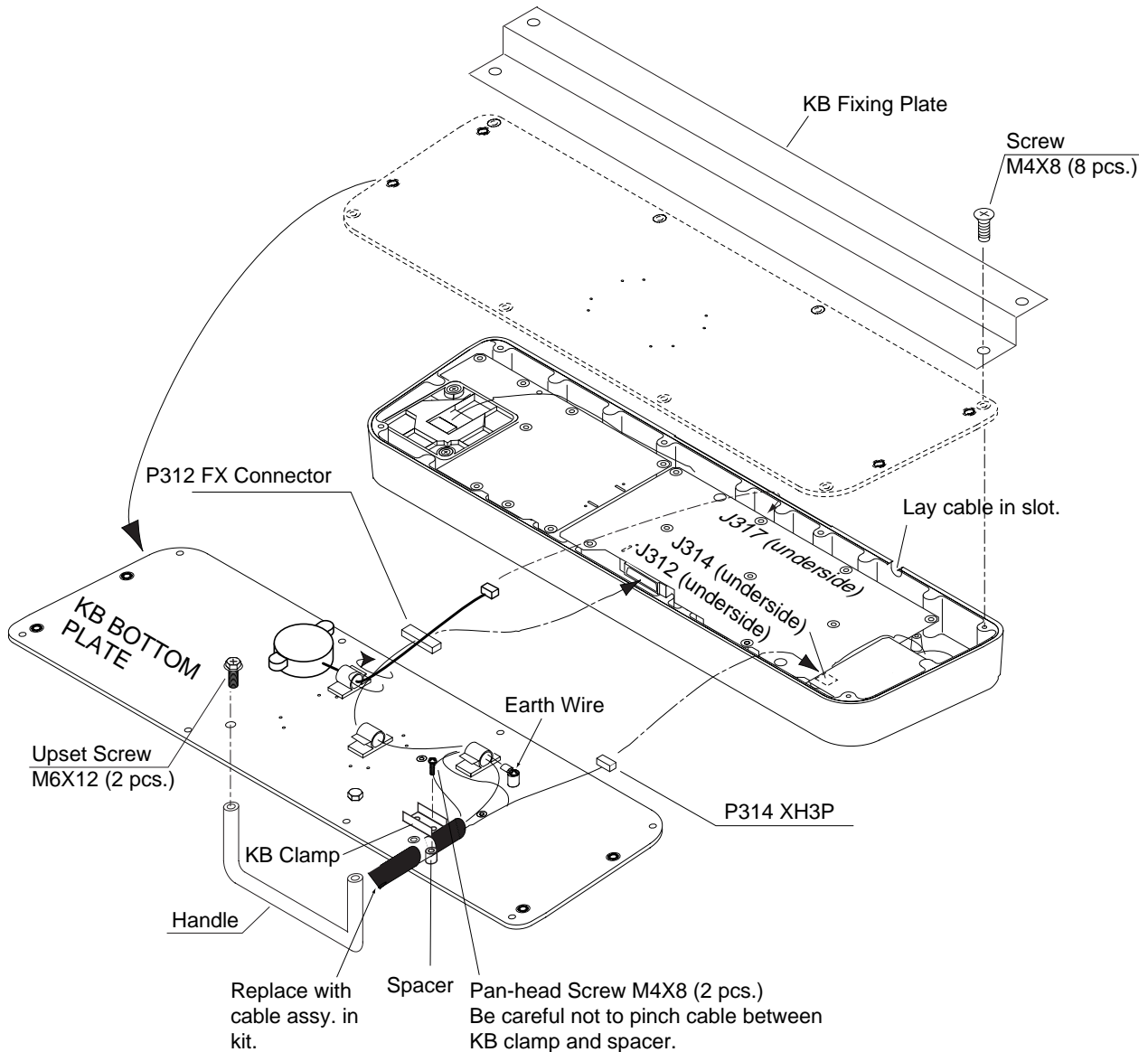

Figure 1-13 Control head

Connection of display unit to control head

1. Attach the handle to the handle plate, using the screws for the handle and bottom cover of the control head.
2. Attach the handle plate to location where the KB arms were fastened.
3. Pull the monitor toward you until you hear click.
4. Lead in the cable assy. (option) from the rear entrance of the display unit. See Chapter 2.
5. Raise the monitor and fix the stay.
6. Inside the display unit, fasten ground wire of the cable assembly with an M4 screw on the chassis.

7. Plug in two connectors of connection cable (P412, J583: See illustration on the previous page.)
8. Lower the monitor.
9. Attach the monitor front cover (option) to the place the panel cover have been, using the screw for the panel cover.
10. Attach rubber to feet to the bottom of the keyboard if the keyboard is not going to be permanently fixed. To fix the keyboard to a desired location, fasten the KB fixing plate to the keyboard and desired location with two upset screws (M5X25, formerly used to fasten KB arms) and two tapping screws ($\phi 6.5$, local supply) as below.

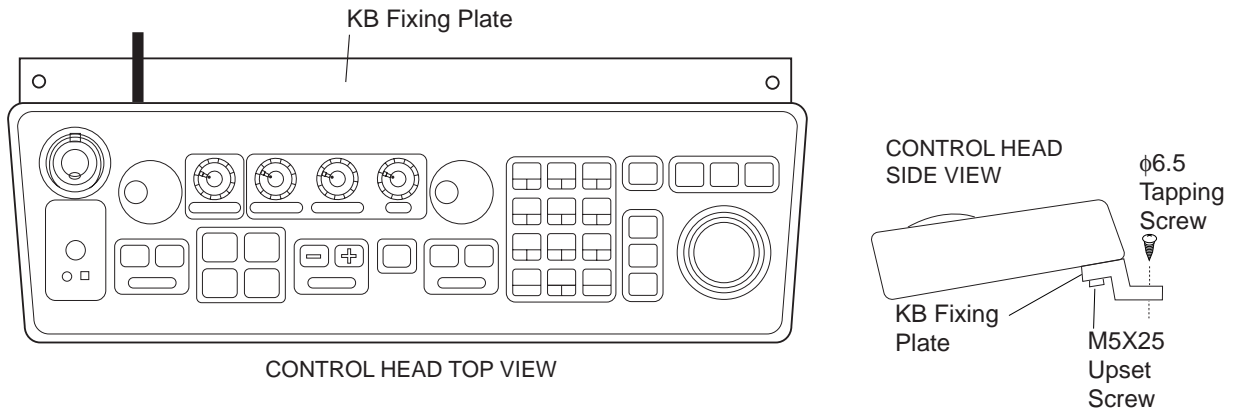

Figure 1-14 How to attach KB fixing plate

11. Set dust cover KB (supplied) on the control head.

Attachment of hood

1. Set two spacers (supplied) to the lower two of the four M5 holes in the CRT panel.
2. Screw two screws (supplied) into the holes in the hood.
3. Set the bottom of the hood to the screws at the bottom of the CRT panel, and then fasten the two screws at the top of the hood to the CRT panel.

1.3 Power Supply Units

The Power Supply Unit PSU-001 (for scanner unit) and PSU-004 (for display unit) do not contain usual operating controls. Therefore, they can be installed in any recessed place either in vertical or horizontal position. (For the console mount display unit, the PSU-004 can be installed inside the console.) However, select a dry and well-ventilated location and observe the compass safe distances below to prevent deviation of a magnetic compass.

	Standard compass	Steering compass
PSU-001 (for scanner unit)	1.20 m	0.90 m
PSU-004 (for display unit)	0.50 m	0.30 m

WIRING

2.1 Scanner Unit

Two signal cables are terminated at the scanner unit: signal cable S03-84 and signal cable 660V-MPYCY-16 from the Power Supply Unit PSU-004.

Preparations

Open the port side cover (six bolts) of the scanner unit. Unfasten fixing plates to access terminal boards.

Signal cable S03-84

1. Shorten the cable, extending the length actually required by 600 mm. Strip off about 600 mm of the anti-corrosive vinyl sheath, and 590 mm of the armor and the inner vinyl sheath being careful not to nick the braided shield.

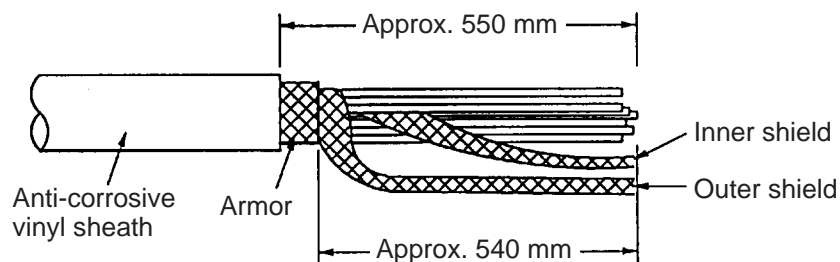

Figure 2-1 Fabricating the signal cable S03-84

2. Turn off the ANT MOTOR SW on the scanner unit(Refer to Figure 1-4).
3. Unravel the outer shield with a screwdriver or similar tool to expose the cores beneath the outer shield.
4. Similar to step 2, expose the cores beneath the inner shield. Mark all cores for future identification.
5. Slide the clamping gland, washers and gasket onto the cable. (Use lower side gland.)

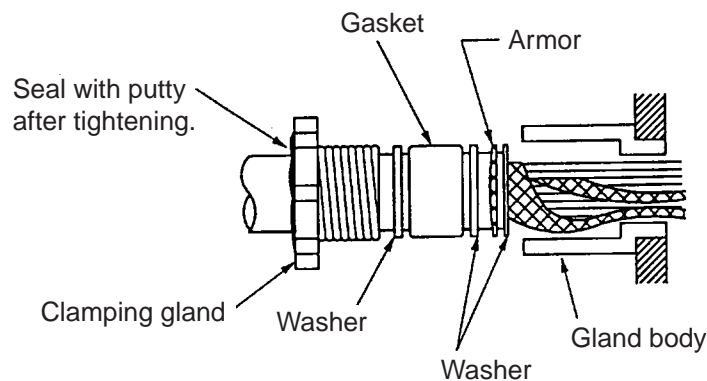

Figure 2-2 Passing clamping gland, washers and gasket on signal cable

6. Ground the armor through the two washers as shown above. Trim the shields considering their location on the earth terminal inside the scanner unit. Fit a crimp-on lug (yellow, FV5.5-4, $\varnothing 4$) to inner and outer shields, then connect them to the ground terminal inside the scanner unit.
7. Determine the length of each core considering its location on STB-1 in the scanner unit (see the interconnection diagram on page S-1). Remove approx. 6 mm of the vinyl insulation from the end of each core and fix the crimp-on lug FV1.25-M3 (Red) to each core.
8. Remove the outer sheath of the coaxial cable (2C-2V) by 75 mm. Pull back the braided shield to expose the inner core. Remove approx. 25 mm of insulator from the end of inner core and fold back conductor as illustrated below. Shorten the shield leaving approx. 45 mm. Fit crimp-on lugs to the conductor (FVD1.25-3, Red) and braided shield (FV1.25-M3, Red).

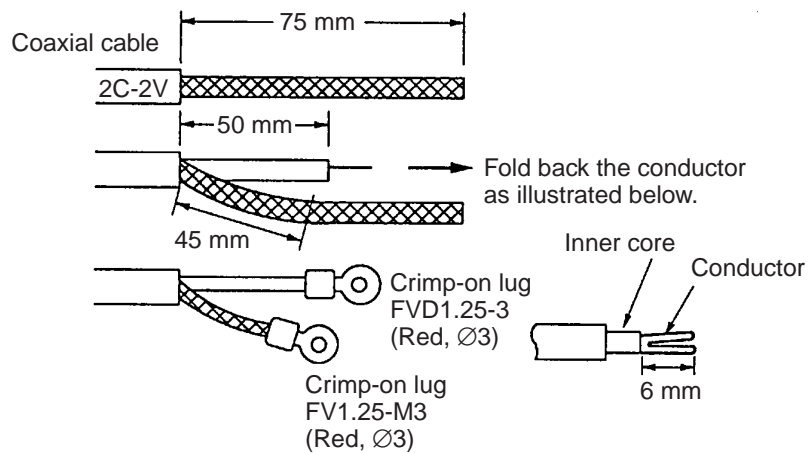

Figure 2-3 Fabrication of coaxial cable

9. Lead cable into cable gland, tighten clamping gland and seal with putty.
10. Connect wiring to terminal STB-1 in the scanner unit referring to the interconnection diagram.

Signal cable 660V-MPYCY-16 (JIS cable)

1. Unfasten the clamping gland from the upper cable gland, and remove the gasket and flat washers.
2. Shorten the cable as appropriate. Remove the vinyl sheath by 600 mm. Remove the armor by 590 mm.

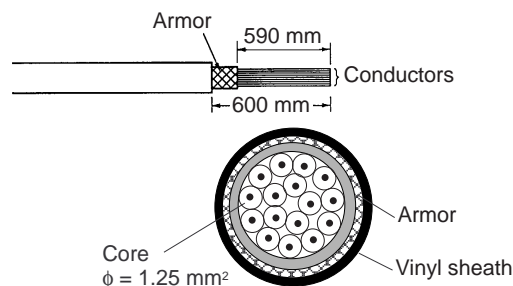

Figure 2-4 Fabrication of signal cable 660V-MPYCY-16

3. Slide the clamping gland, washers and gasket on the power cable. Fold back the armor by 5 mm, then put it between washer and cable gland body as below.

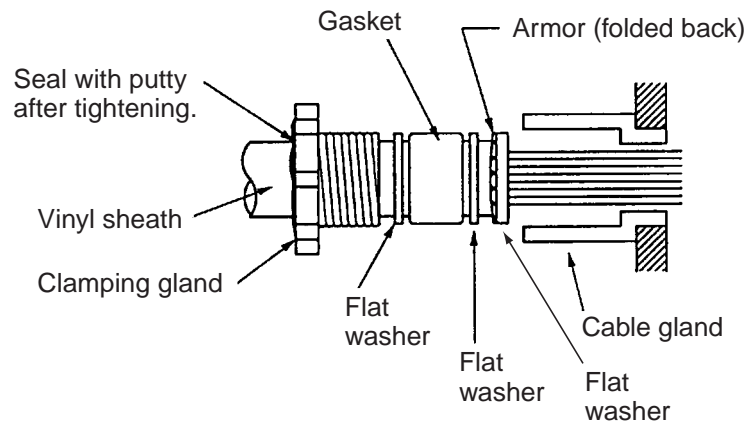

Figure 2-5 Passing clamping gland, washers and gasket on the signal cable

4. Determine the length of the cores considering their location on STB-2 and STB-3. Trim conductors as necessary.
5. Ground the armor by inserting it through the two flat washers near the cable gland.
6. Remove the sheath of each core by 6 mm. Fix crimp-on lugs (FV1.25-4, blue, $\varnothing 4$) to each conductor. Make sure each connection is secure both electrically and mechanically.
7. Lead cable into cable gland, tighten clamping gland and seal with putty.
8. Connect the conductors to STB-2 and STB-3, referring to the interconnection diagram on page S-1.
9. Check for loose screws and poor contact on crimp-on lugs. Close terminal boards.
10. Grease the fixing bolts for the cover, gasket and tap holes in the scanner chassis. Attach cover.

When the de-icer is installed

- 1) Before beginning any work on the scanner unit, turn off the breaker for the de-icer line at the main switchboard to remove the power (100 VAC, 1 \varnothing) to the de-icer. (Turning off the power to the display unit has no effect.)
- 2) The neck of the scanner unit becomes VERY HOT when the de-icer is working. (The de-icer turns on when ambient temperature is below 0°C.)

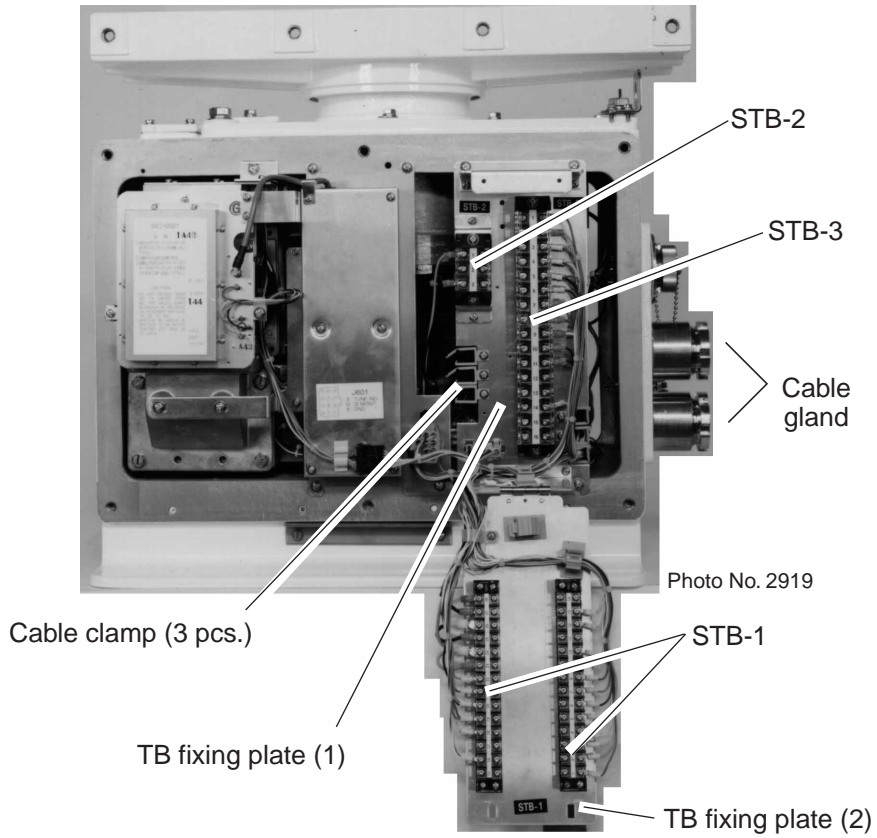

Figure 2-6 Scanner unit, port side view

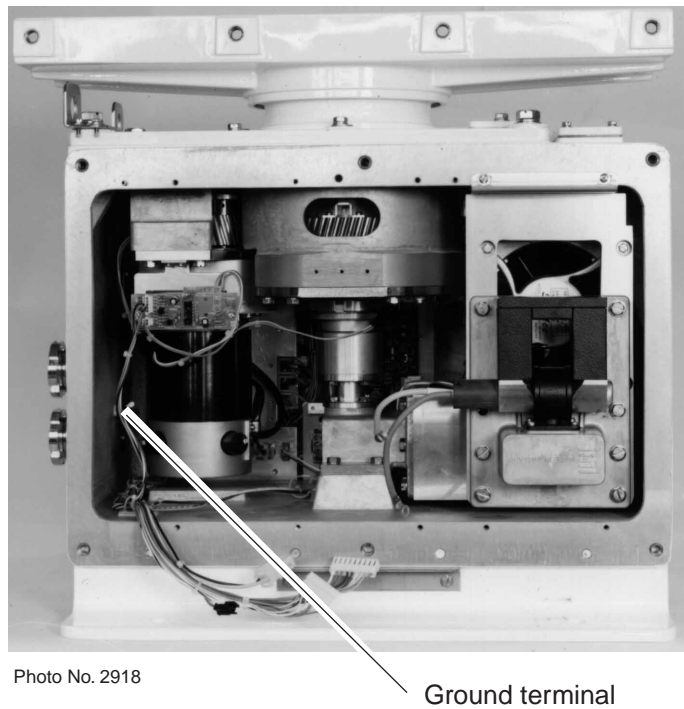
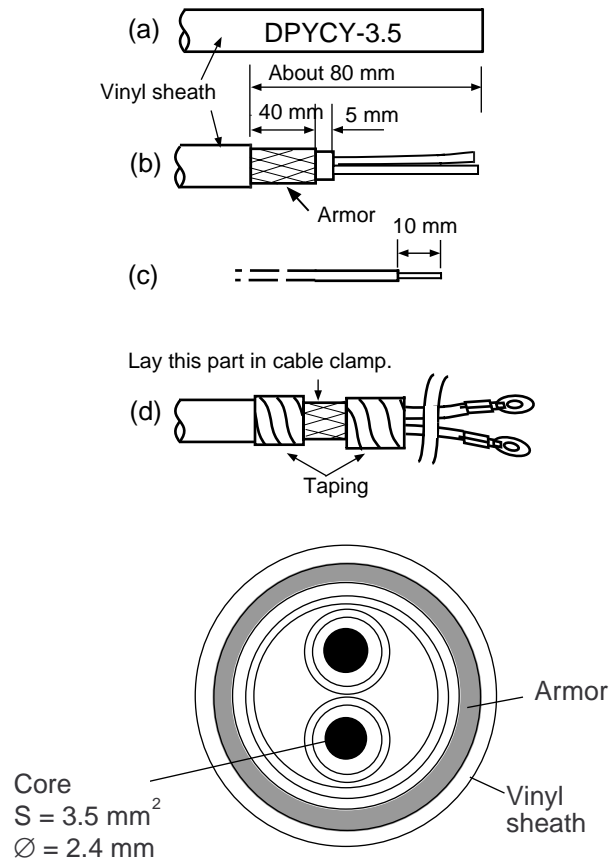

Figure 2-7 Scanner unit, starboard side view, Tx chassis removed

2.2 Display Unit

Fabricating the power cable DPYCY-3.5 (JIS cable)

1. Remove the vinyl sheath by 80 mm.
2. Cut off jute tape wrapped around the armor.
3. Unravel the armor to expose the cores by about 35 mm.
4. Remove insulation of cores by about 10 mm. Fix crimp-on lugs to the cores and armor.
5. Cover the armor with vinyl tape, leaving the portion which will lie inside the cable clamp untaped.



DPYCY-3.5 sectional view

Figure 2-8 Fabrication of power cable DPYCY-3.5 (JIS cable)

Leading in cables to the display unit

The cable clamp may be positioned inside the display unit (default arrangement), outside the display unit or at the bottom of the display unit (when using console mount). When the cable clamp is located outside or beneath the display unit, use the bottom clamp front plate and bottom clamp rear plate (supplied with installation materials).

Also, use the shielding foam (supplied) to protect against noise radiation.

Cable fed from back of display unit (default method)

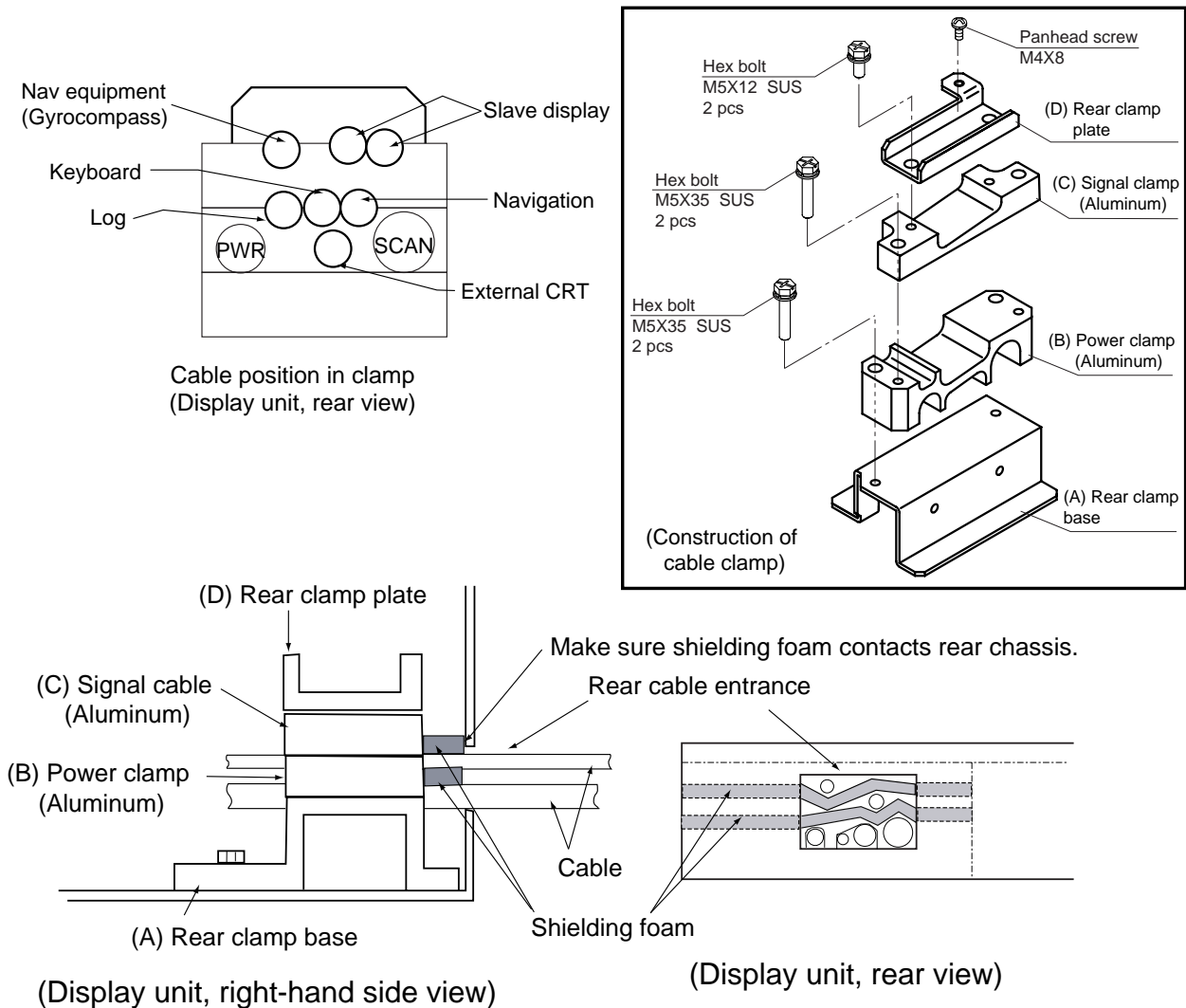
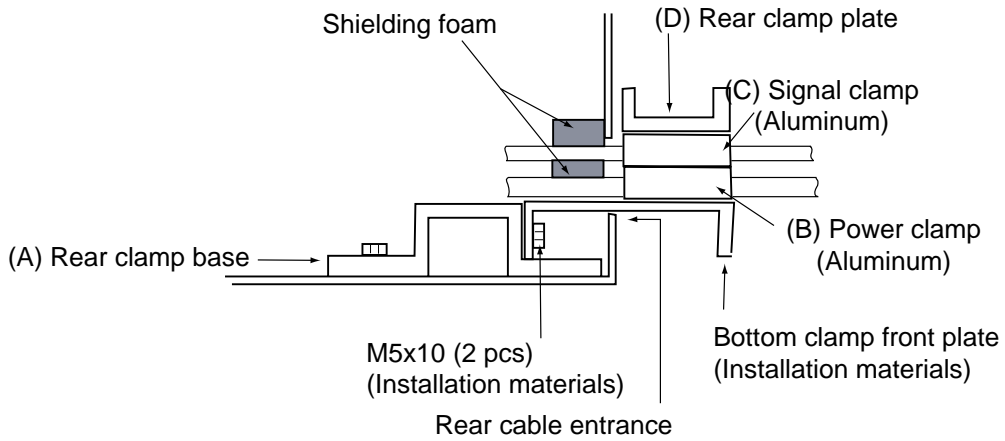

Figure 2-9 Default cable clamp position

- Place shielding foam between cables, and then attach the foam to aluminum clamps.
- Fill unused clamp holes with shielding foam.

Cable fed from outside display unit



(Display unit, right-hand side view)

Figure 2-10 Clamp position outside display unit

- Place shielding foam between cables inside of display unit, and then attach foam to chassis.
- Fill unused clamp holes with shielding foam.

Cables fed from bottom of display unit (for console mount)

Lead in cables through the cable clamp at the rear of the console and ground their shields in the cable clamp. For signal cable, remove vinyl sheath where cable lies in cable clamp. Fasten cables with cable ties.

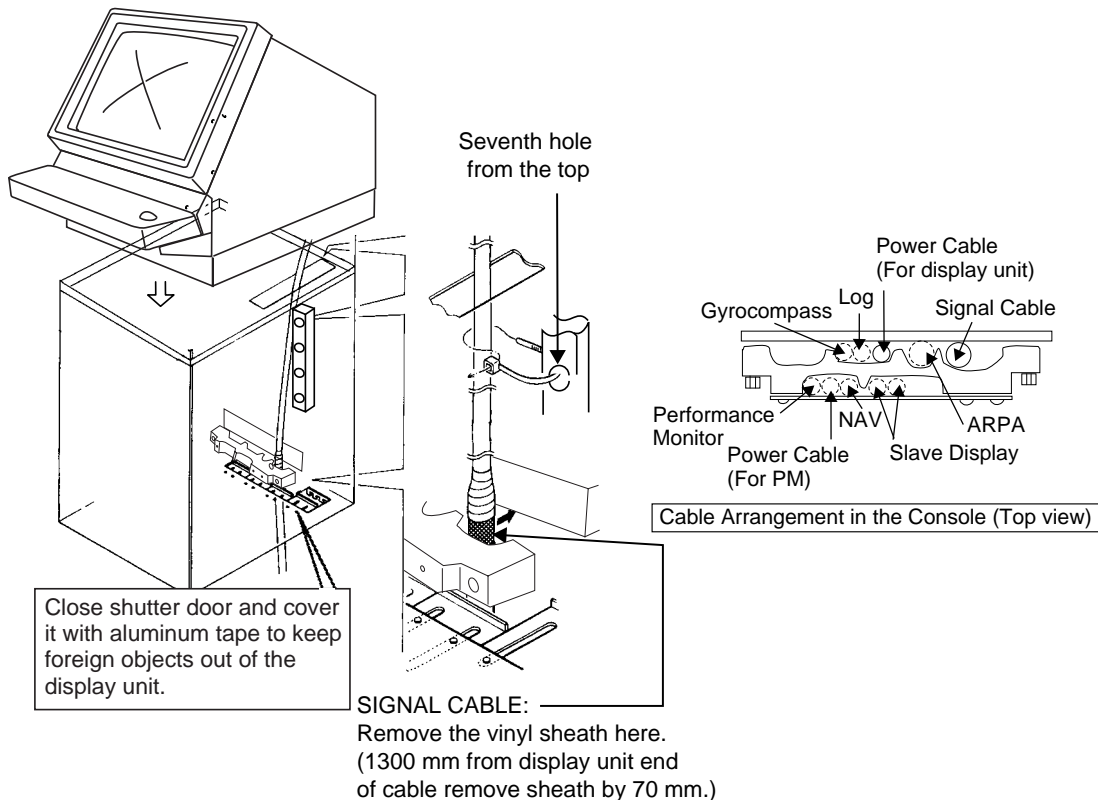

Figure 2-11 Clamp position at bottom of display unit

Connections

Open the display unit and fix it with the stay. (For procedure see page 1-6.) Remove the shield cover from the INT Board. Connect signal, power, gyro and log cables as shown on the next page. Optional equipment are connected to the INT Board. Be sure to ground the display unit.

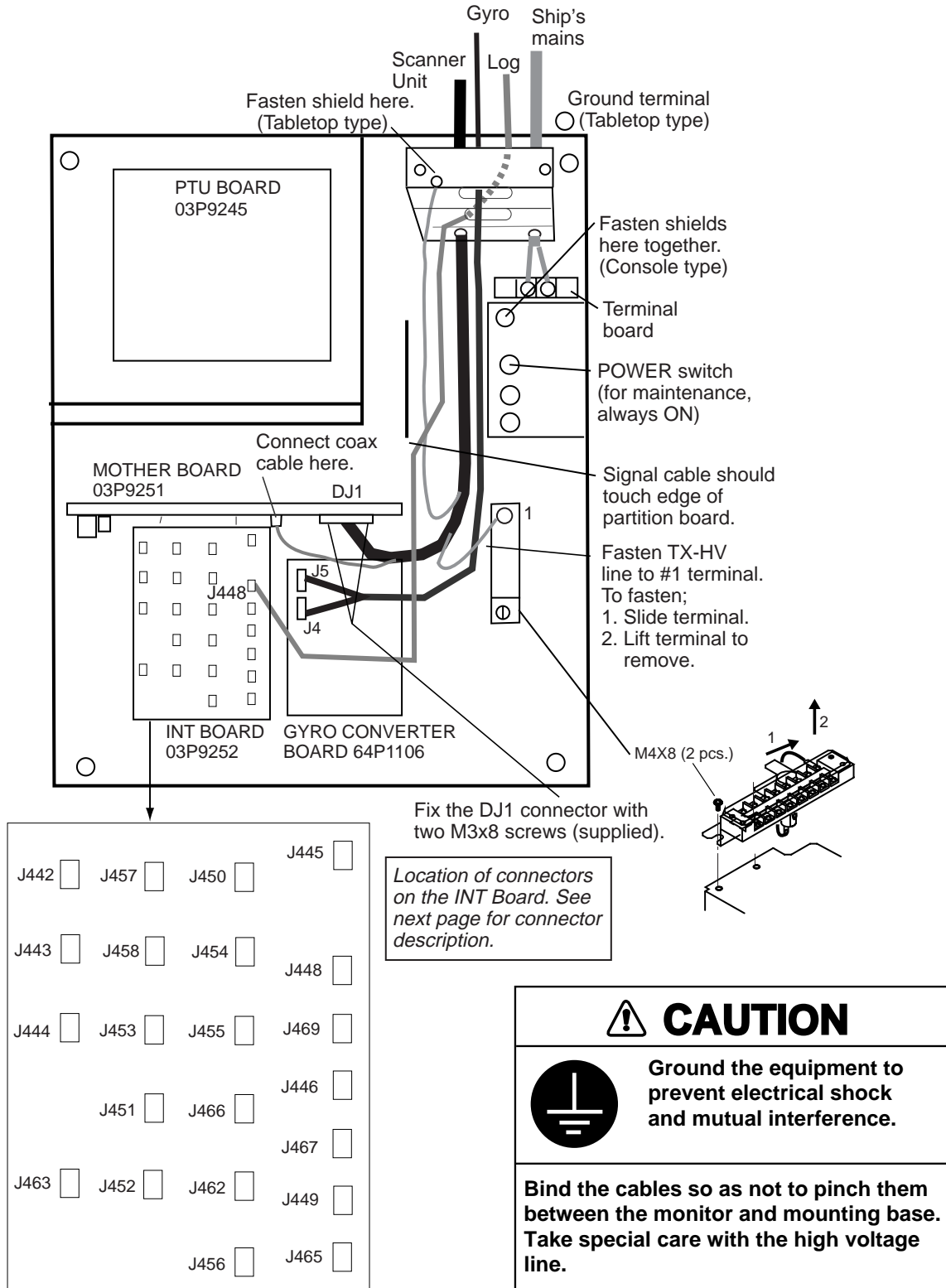

Figure 2-12 Display unit, inside view

Connectors on the INT Board

Table 2-1 Connectors on the INT Board

Signal name	Name on pcb	Connector no.	Connector type	Applicable equipment	Remarks
Input Signal					
Gyro signal		J4	VH, 3 pin		*: On pcb A64P1106 (option)
		J5	VH, 5 pin		
Speed log signal	LOG	J448	NH, 3 pin		200 pulses/nm, etc.
Radar buoy signal	RADAR BUOY	J445	NH, 4 pin		
Remote display signal	EXT-RADAR or RJ-7	J458	NH, 8 pin		
Output Signal					
External ARPA signal	EXT-ARPA	J444	NH, 8 pin		Heading, bearing, Tx trigger
Slave display signal	SLAVE	J442 J443	NH, 8 pin	CD-140, CD-141, GD-500, GD-500MK2, FMD-800, FMD-8010 *1	Heading, bearing, video, Tx trigger
Buzzer signal	EXT-BUZ	J451	NH, 9 pin	Speaker w/amp	Speaker signal
Monitor signal		J449	NH, 10 pin		VER synchronous, HOR synchronous, video (NTSC format)
RS-232C	RS-232C	J456	NH, 4 pin		
Analog	ANALOG	J453	NH, 3 pin		
External buzzer	EXT ALARM (AC)	J452	NH, 3 pin		
Input/Output Signal					
INS data	INS. DATA	J455	NH, 5 pin		
RJ-7	RJ-7	J457	NH, 15 pin		
RJ-8	RJ-8	J416	NH, 4 pin		On Mother Board 03P9251
Nav data	NAV DATA	J450	NH, 5 pin		
ARPA data	ARPA DATA	J454	NH, 5 pin		
PM_ON_OFF	PM_PINT	J411	XH, 3 pin		On Mother Board 03P9251

Note: How to attach NH connector is shown on the next page.

How to attach NH connector

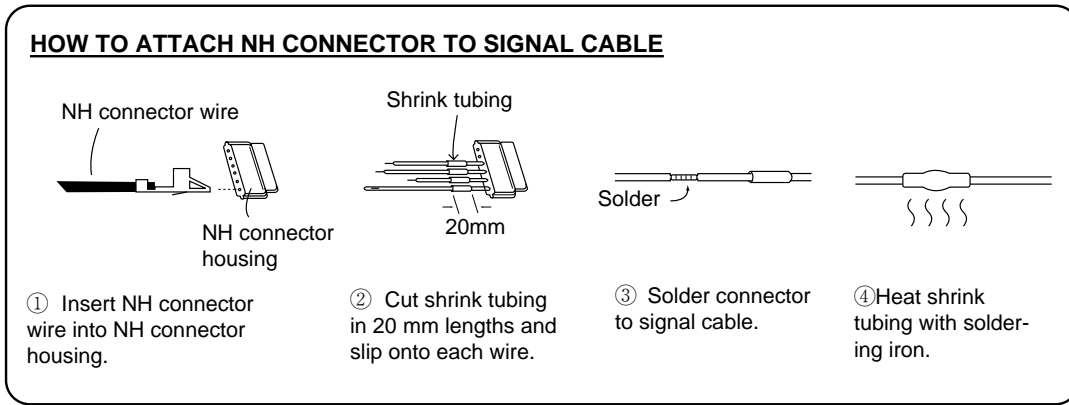

Figure 2-13 How to attach NH connector

2.3 Changing AC Power Specification of Display Unit

To operate the display unit from 100 VAC or 220 VAC power, add or delete jumper wires on the PTU Board and change the power fuses inside the display unit as shown in the table below according to ship's mains. The figure below shows the location of the power fuses and the jumper wires on the PTU Board.

Table 2-2 Jumper wire setting on the PTU board, fuse rating and power specification

PCB	Power Spec.	Antenna rpm	JP1	JP2	JP3	JP4	JP91	JP92	Power Fuses
03P9245A	100/110/115 VAC	24 rpm	YES	YES	YES	NO	NO	NO	10A
03P9245D	220/230 VAC	24 rpm	NO	NO	NO	YES	NO	NO	5A

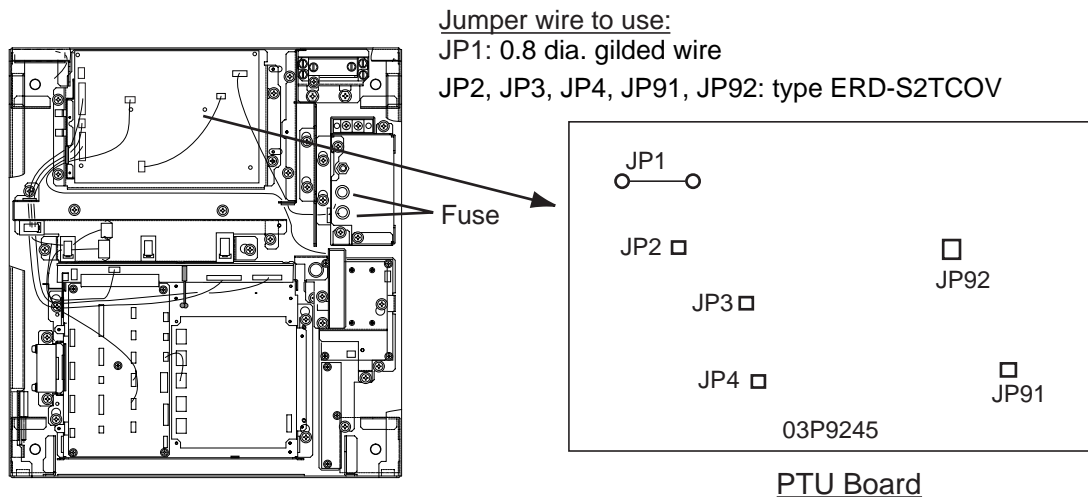

Figure 2-14 Display unit, inside view

2.4 Power Supply Units

Power supply unit PSU-001 (for scanner unit)

Two cables run to the Power Supply Unit PSU-001, the power cable (DPYC-3.5) from the Power Supply Unit PSU-004 and the signal cable (660V-MPYCY-16) from the scanner unit.

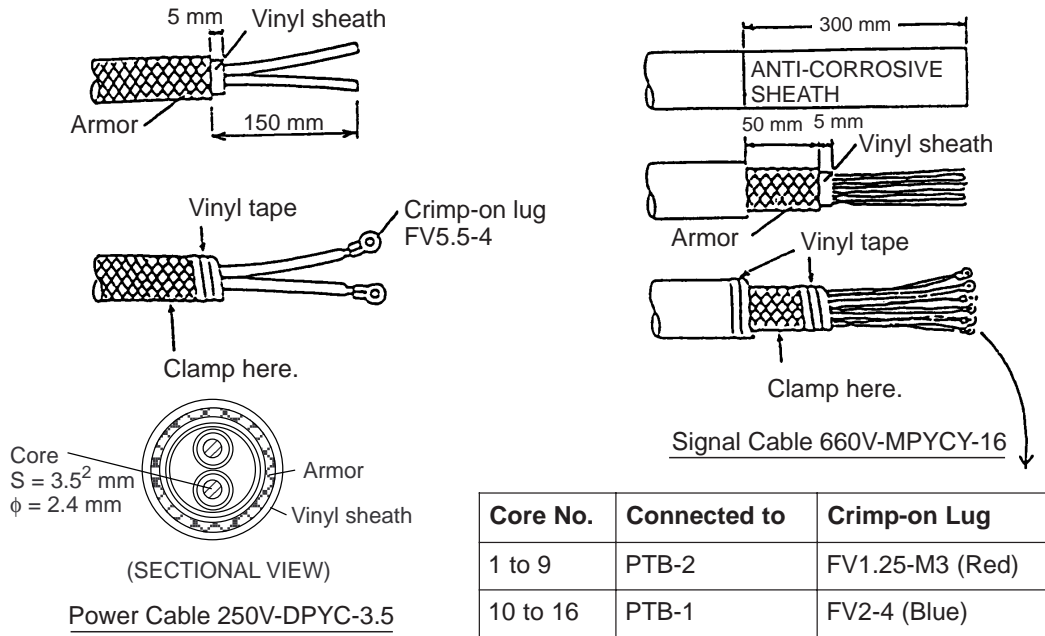

Figure 2-15 Fabrication and connection of power cable and signal cable

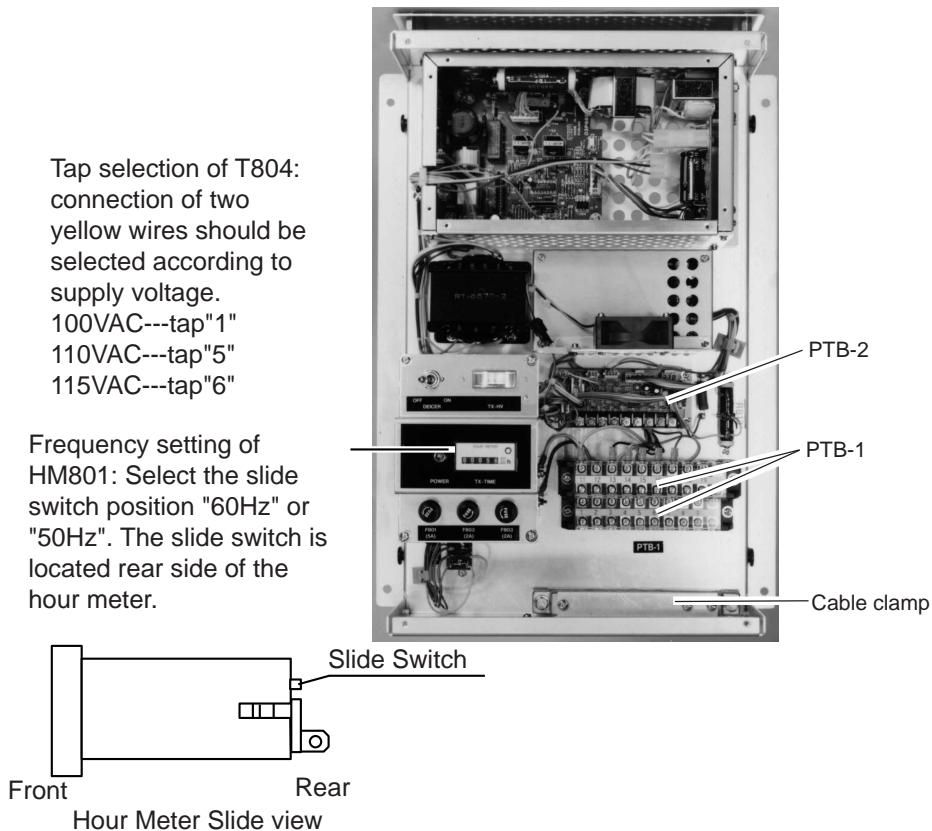

Figure 2-16 Power supply unit PSU-001

Power supply unit PSU-004 (for display unit)

Wire the Power Supply Unit PSU-004 as shown in the interconnection diagram.

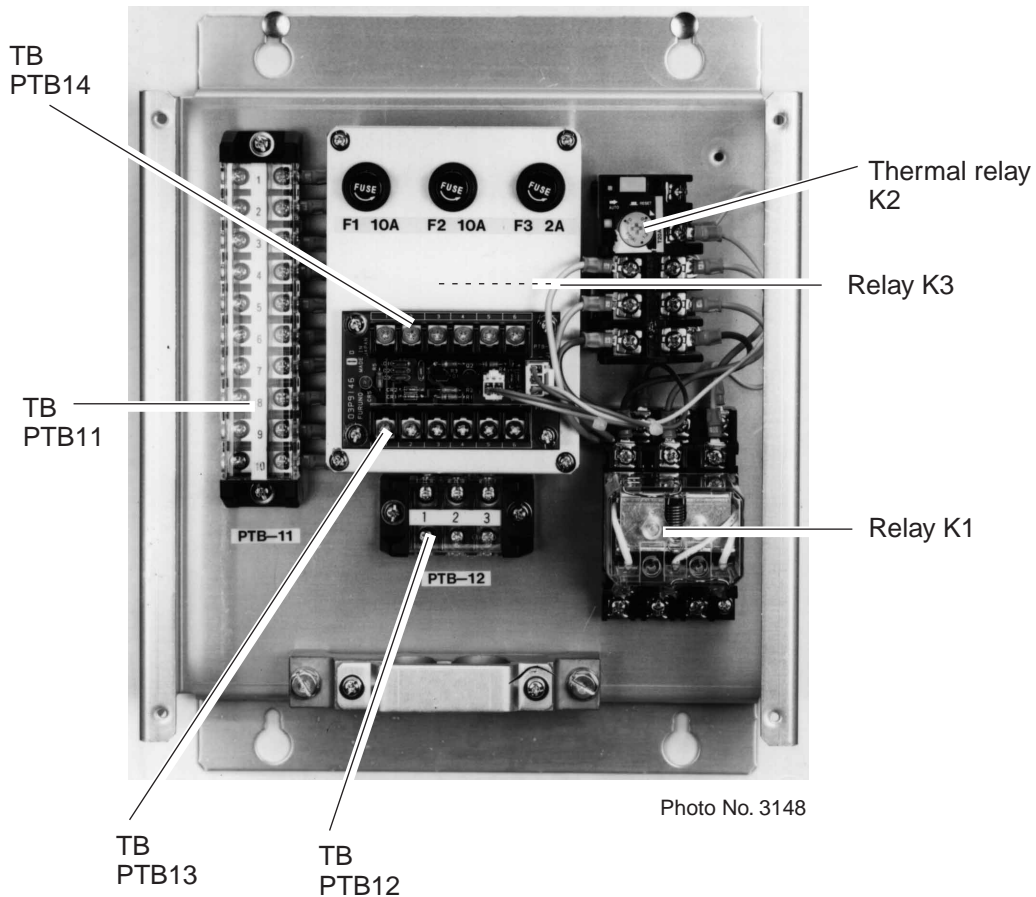

Figure 2-17 Power supply unit PSU-004

The type and rating of the thermal relay (K2) are as below.

Ship's Mains	Scanner Unit	Thermal Relay (K2)	
		Type	Rating
24 VDC	RSB-0051	BAC101505D	5A

Short Terminals !

Short between #4 and #6 on PTB14.

2.5 Installation and Connection of Rectifier Unit

For operation from ship's mains of 100/110/115/220/230 VAC, the rectifier unit RU-3423 is required. The rectifier unit can be installed in any dry, well-ventilated place. Connect AC ship's mains to the rectifier as below.

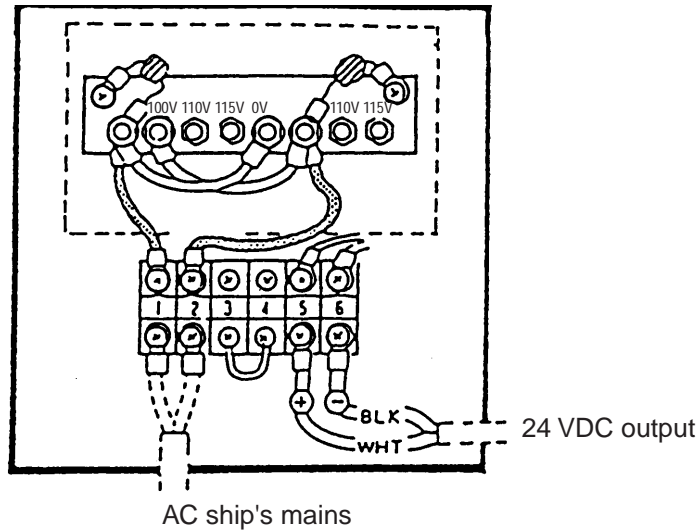

Connections for 100 VAC ship's mains

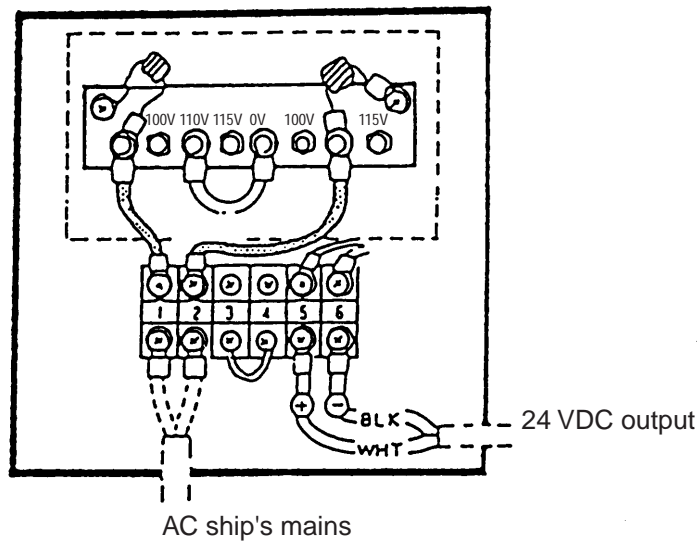

Connections for 220 VAC ship's mains

Figure 2-18 Rectifier unit connections

INITIALIZATION AND ADJUSTMENT

3.1 Tuning Initialization

Tune the radar as follows: Press [RADAR MENU] [0] [0] [2] [0] [0] [0] (TUNE INITIALIZE on RADAR 3 menu) and press the [ENT] key. Also, confirm that "2.MODEL" is set to "2165DS" in the INITIAL SETTING 4 menu, referring to page 3-6. If the setting is wrong, trouble may result.

3.2 Accessing Menus for Initialization and Adjustment

To access them do the following:

1. Turn on the power.
2. Press the [RADAR MENU] key five times while pressing and holding down the [HL OFF] key.

Restoring default settings

1. Press [RADAR MENU] [0] [0] [0] [2] [0] [0] [0] to display the INITIAL SETTING 4 menu.
2. Press the [0] key to select FACTORY DEFAULT.

3.3 Adjusting Video Signal Level

When the signal cable is very long, the video amplifier input level decreases, shrinking target echoes. To prevent this, confirm (and adjust if necessary) video amplifier input level.

1. Connect an oscilloscope to TP6 on the INT Board (03P9252) in the display unit.
2. Transmit on the 12 nm range.
3. Adjust R21 on the INT Board so the value of TP6 is 4 Vpp. (For remote display, adjust R134 on the INT Board.)

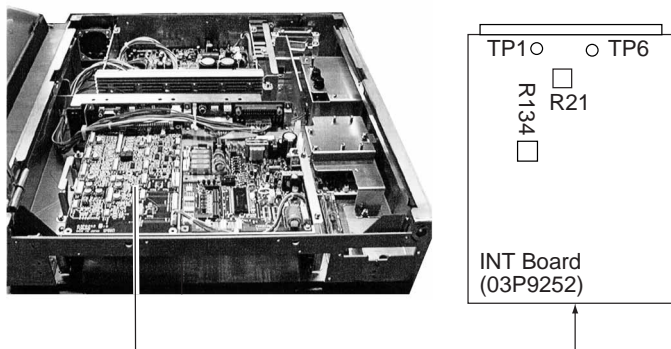

Figure 3-1 Display pedestal

3.4 Heading Alignment

You have mounted the scanner unit facing straight ahead in the direction of the bow. Therefore, a small but conspicuous target dead ahead visually should appear on the heading line (zero degrees).

In practice, you will probably observe some small bearing error on the display because of the difficulty in achieving accurate initial positioning of the scanner unit. The following adjustment will compensate for this error.

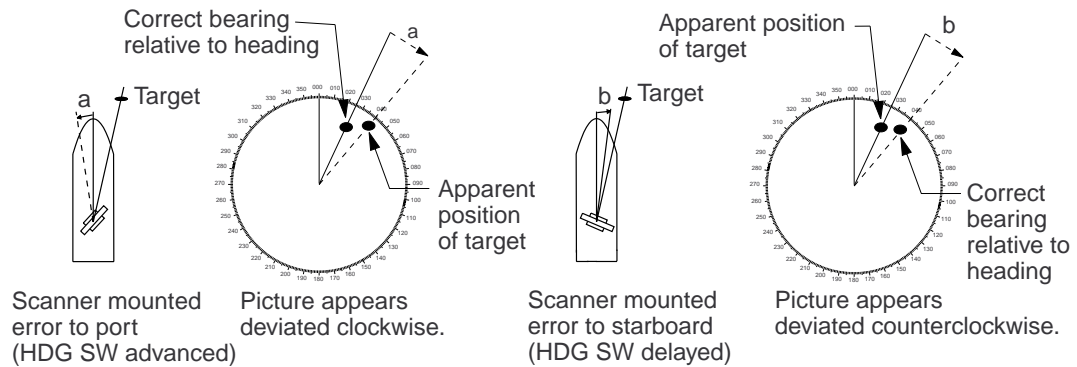

Figure 3-2 Heading alignment

1. Turn on the power. Press [RADAR MENU] [0] [0] [0] [2] [2] to select HL ALIGN on the INITIAL SETTING1 menu.
2. Select a target echo (by gyrocompass, for example) at a range between 0.125 and 0.25 nm, preferably near the heading line.
3. Operate the EBL control to bisect the target echo with the heading line. (The value shown on the display is scanner position in relation to ship's bow.)
4. Press [ENTER] to finish.

3.5 Adjusting Sweep Timing

Sweep timing differs with respect to the length of the signal cable between the scanner unit and the display unit. Adjust sweep timing at installation to prevent the following symptoms:

- The echo of a "straight" target (for example, pier), on the 0.25 nm range, will appear on the display as being pulled inward or pushed outward. See Figure 3-3.
- The range of target echoes will also be incorrectly shown.

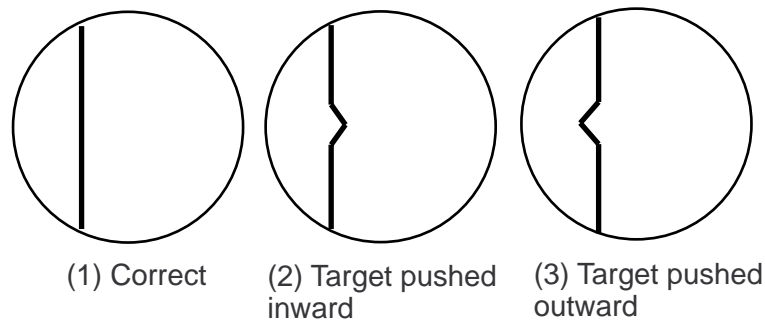

Figure 3-3 Examples of correct and incorrect sweep timings

1. Turn on the power. Press [RADAR MENU] [0] [0] [0] [2] [3] to select TIMING ADJ on the INITIAL SETTING1 menu.
2. Transmit on the 0.25 nm range.
3. Adjust radar picture controls to display picture properly.
4. Select a target echo which should be displayed straightly.
5. Adjust the VRM control to straighten the target echo.
6. Press [ENTER].

3.6 Suppressing Main Bang

If main bang appears at the screen center, suppress it as follows.

1. Turn on the power. Transmit on a long range and then wait ten minutes.
2. Adjust [GAIN] control to show a slight amount of noise on the display.
3. Select the 0.25 nm range. Adjust the [A/C SEA] control to suppress sea clutter.
4. Press [RADAR MENU] [0] [0] [0] [2] to open the INITIAL SETTING1 menu.
5. Press [7] to select 7.MBS.
6. Adjust the VRM control to adjust timing; the EBL control to adjust level.
7. Press [ENTER].

3.7 Confirming Magnetron Heater Voltage

Magnetron heater voltage is adjusted at the factory with a 15 m signal cable. Therefore, when the signal cable is longer than 15 m, confirm that magnetron heater voltage is within the prescribed rating as follows:

1. Disconnect P821 from the scanner unit.
3. Turn on the radar and press [RADAR MENU] [0] [0] [0] [2] [0] to open the INITIAL SETTING2 menu.
4. Press [5] to select the 5. SCANNER STOPPED field and the TX option.
5. Set the range to 0.125 nm.
6. Turn off the antenna switch in the display unit.

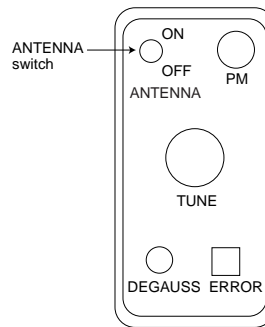

Figure 3-5 Antenna switch in tuning compartment

7. Connect a multimeter, set to the 10 VDC range, between J829 #1 (+) and #2 (-) in the scanner unit.
8. Adjust the position of the sliding contact R812 to show a value between 7.0 V and 7.6 V on the multimeter.
9. Remove the TX-HV fuse (F801, 0.5A) from the power supply unit.
10. Transmit on maximum range.
11. Adjust the position of the sliding contact R811 to show a value between 4.7 V and 5.3 V on the multimeter.
12. Insert TX-HV fuse F801.
13. Press [RADAR MENU] [0] [0] [0] [2] [0] [5] to select the 5. SCANNER STOPPED field and the TX option.
14. Turn on the ANT MOTOR SW on the scanner unit (Refer to Figure 1-4).

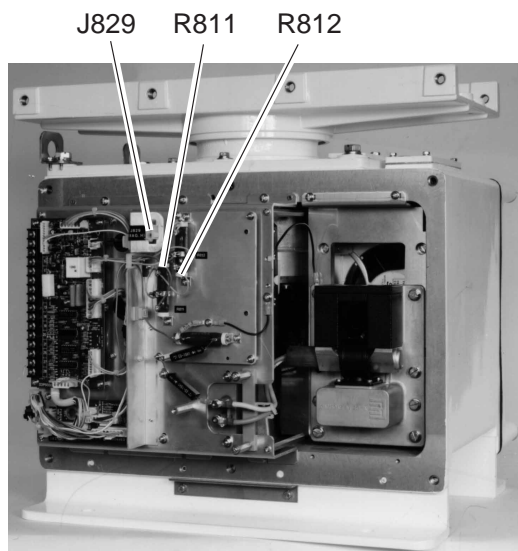

Photo No. 2917

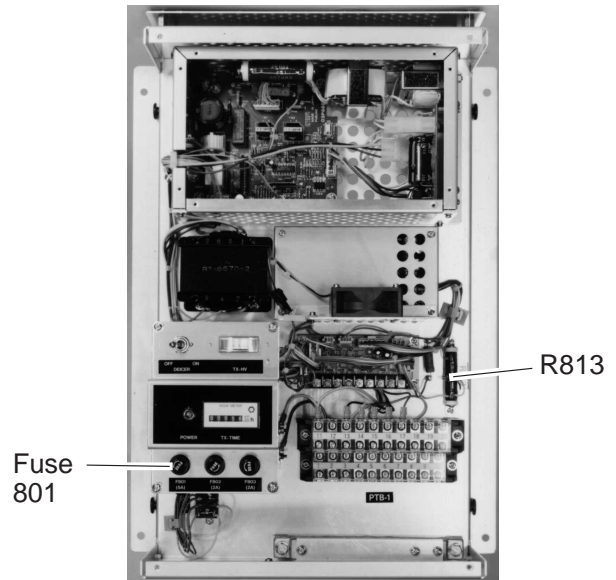

Photo No. 2914

Figure 3-6 Scanner unit, power supply unit PSU-001

Note: When the length of the cable between the scanner unit and the power supply unit is more than 60 meters, the magnetron heater voltage may not reach the lower limit due to voltage drop. If this is the case, increase the voltage with the sliding contact R813 in the power supply unit, and readjust with R811, R812 in the scanner unit.

3.8 Initial Setting Menus

The INITIAL SETTING menus (four menus) and the OWN SHIP INFORMATION menu setup the radar according to expected usage, authorities specification, ship's characteristics, operator's preference, etc. Set items on each menu in accordance with regulations/operator's preference. After entering initial settings, reset the power.

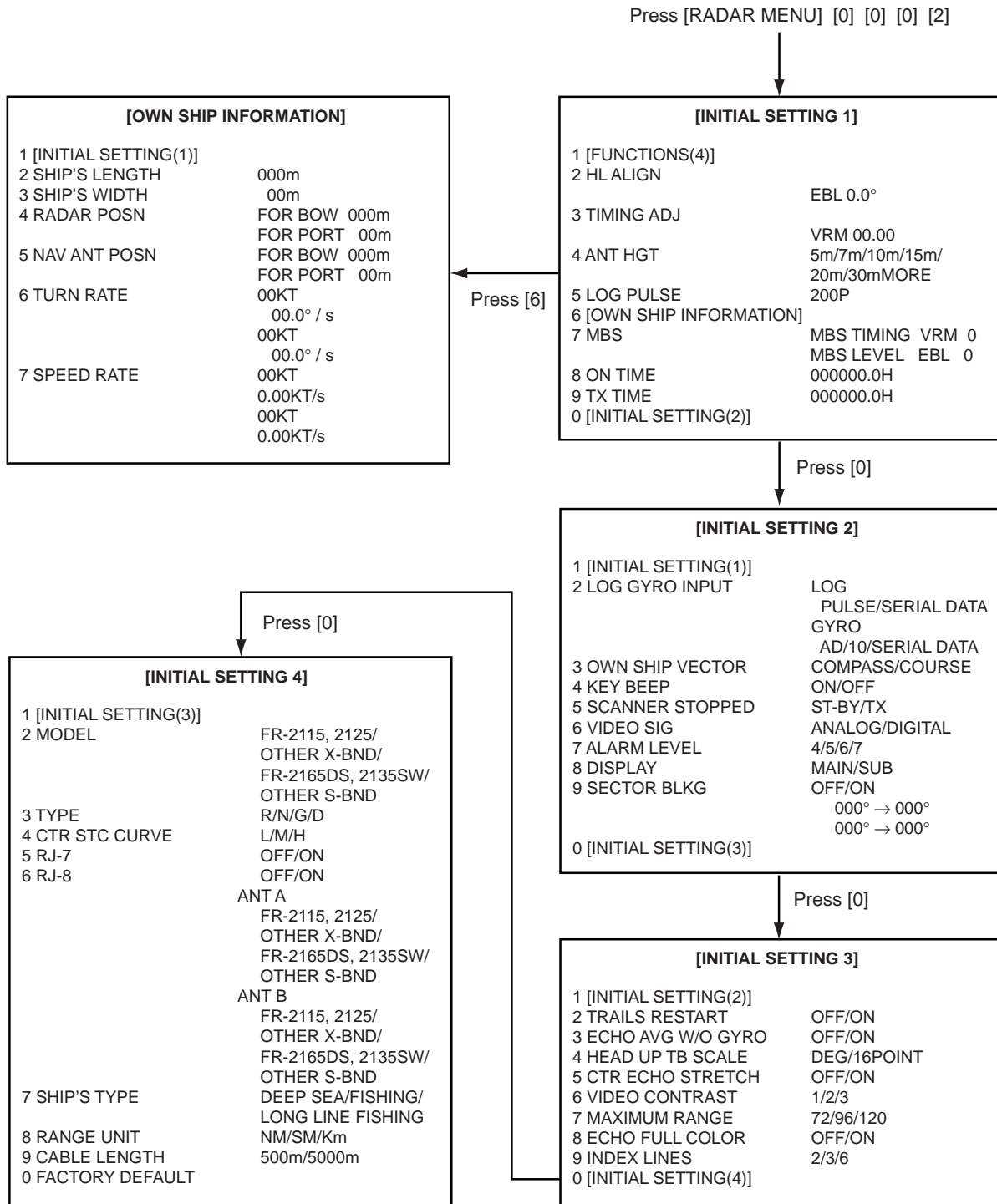

INITIAL SETTING1 menu

Keying sequence: [RADAR MENU] [0] [0] [0] [2]

HL ALIGN: Aligns heading.

TIMING ADJ: Adjusts sweep timing.

ANT HGT: Enter height of scanner above water. Select from 5 m, 7 m, 10 m, 15 m, 20 m, or more than 30 m.

LOG PULSE: Enter speed log's pulse rate.

OWN SHIP INFORMATION: Enter ship's characteristics; length, width, radar scanner position, navigation antenna position, turn rate, and speed rate. See the description on the next page for further details.

MBS: Suppresses main bang.

ON TIME, TX TIME: Shows number of hours the radar has been turned on and transmitted, respectively. Value can be changed.

INITIAL SETTING2 menu

Keying sequence: [RADAR MENU] [0] [0] [0] [2] [0]

LOG GYRO INPUT: Select LOG or GYRO input type. LOG: Select pulse or serial data. GYRO: Digital from A/D converter or serial data.

OWN SHIP VECTOR: Select reference for own ship vector; compass or course.

KEY BEEP: Turns key response beep on or off.

SCANNER STOPPED: Set to ST-BY in normal use. TX enables transmission state without scanner rotation.

VIDEO SIG: Set to ANLG (analog) for normal use. Select DIGITAL to adjust QV (Quantized Video).

ALARM LEVEL: Sets echo strength which triggers guard alarm. "7" is strongest echo; "4" is medium strength echo.

DISPLAY: Select radar display function; main or sub (slave).

SECTOR BLKG: Sets area (up to 2) where no radar pulses will be transmitted. For example, set the area where an interfering object at the rear of the scanner would produce a dead sector (area where no echoes appear) on the display. To enter an area, select ON and enter relative bearing range of the area.

INITIAL SETTING3 menu

Keying sequence: [RADAR MENU] [0] [0] [0] [2] [0] [0]

TRAILS RESTART: Selects whether to restart or discontinue target trails when changing the range. ON restarts trailing on newly selected range; OFF discontinues trails.

ECHO AVG W/O GYRO: Echo averaging can be turned on without gyrocompass connection.

HEAD UP TB SCALE: Bearing scale may be shown in degrees or compass points in the head-up mode.

CTR ECHO STRETCH: Turn on to enlarge echoes in the range up to the first range ring.

VIDEO CONTRAST: For factory use. Do not change setting.

MAXIMUM RANGE: For factory use. Do not change setting.

ECHO FULL COLOR: Echoes may be displayed in one color or multi-color. Select ON for multi-color display.

INDEX LINES: Selects the number of index lines to display; 2, 3, or 6.

INITIAL SETTING4 menu

Keying sequence: [RADAR MENU] [0] [0] [0] [2] [0] [0] [0]

MODEL: Selects radar model.

TYPE: Selects specification of radar. Select R for R type; G for IMO type.

CTR STC CURVE: Selects level of STC affect; Low, Medium or High.

RJ-7, RJ-8: Selects which Interswitch unit to use.

SHIP'S TYPE: Select class of vessel; deep sea, fishing, long line fishing.

CABLE LENGTH: Set for "500."

FACTORY DEFAULT: Restores all menus' default settings.

OWN SHIP INFORMATION menu

Keying sequence: [RADAR MENU] [0] [0] [0] [2] [6]

SHIP'S LENGTH: Enter ship's length.

SHIP'S WIDTH: Enter ship's width.

RADAR POSN: Enter distance from both bow and port to the radar scanner location.

NAV ANT POSN: Enter distance from both bow and port to the navigation antenna location.

TURN RATE: Enter ship's turn rate.

SPEED RATE: Enter ship's speed rate.

INSTALLATION OF OPTIONAL EQUIPMENT

4.1 Gyro Converter GC-8

The Gyro Converter GC-8, incorporated inside the radar display unit, converts analog gyrocompass reading into digital coded bearing data for display on the radar display.

This section explains how to install and setup the GC-8 (mainly consisting of the GYRO CONVERTER Board) and set it up according to gyrocompass connected.

Installation and connection of the GYRO CONVERTER Board

Necessary Parts: GC-8-2 (008-446-520)

Name	Type	Qty	Code No.
Gyro Converter Board	64P1106	1	004-412-220
Screws	M3x8, C2700W	5	000-881-404
Sticker	64-014-20211	1	100-132-701

- 1) Turn off the power.
- 2) Open the display unit. See Chapter 1 for instructions.
- 3) Fasten the GYRO CONVERTER Board inside the display unit with four washerhead screws (supplied).

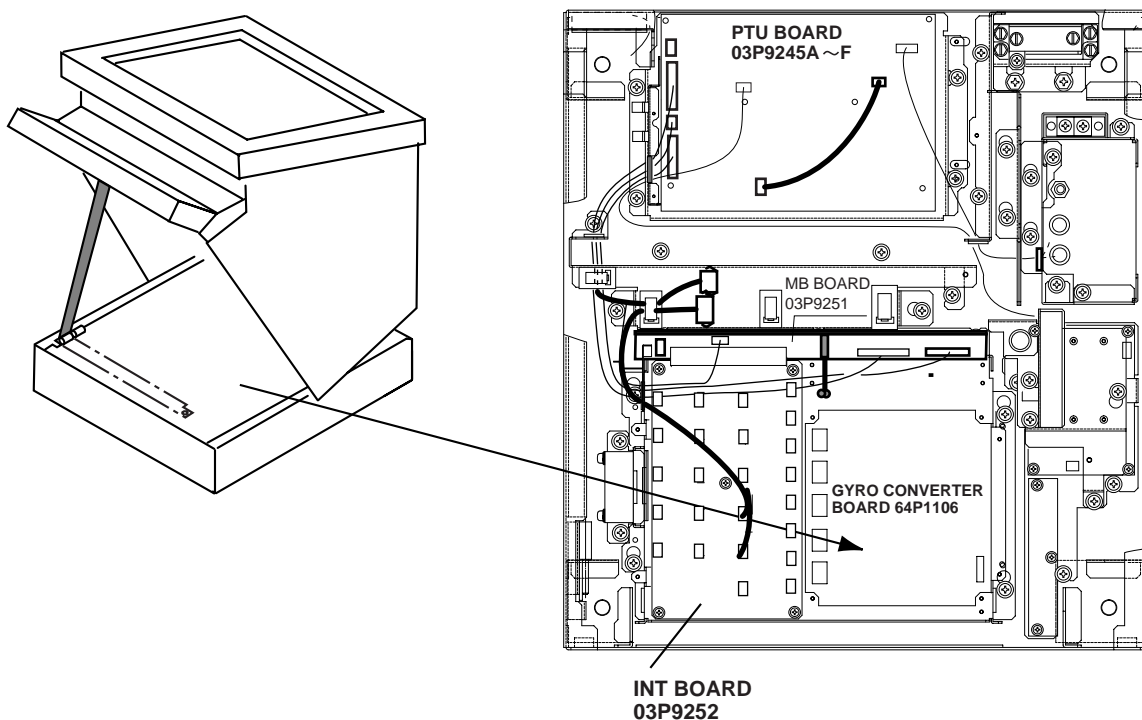

Figure 4-1 Display unit, inside view

- 4) Connect the GYRO CONVERTER Board to the INT Board (cables supplied with GC-8) as shown below.

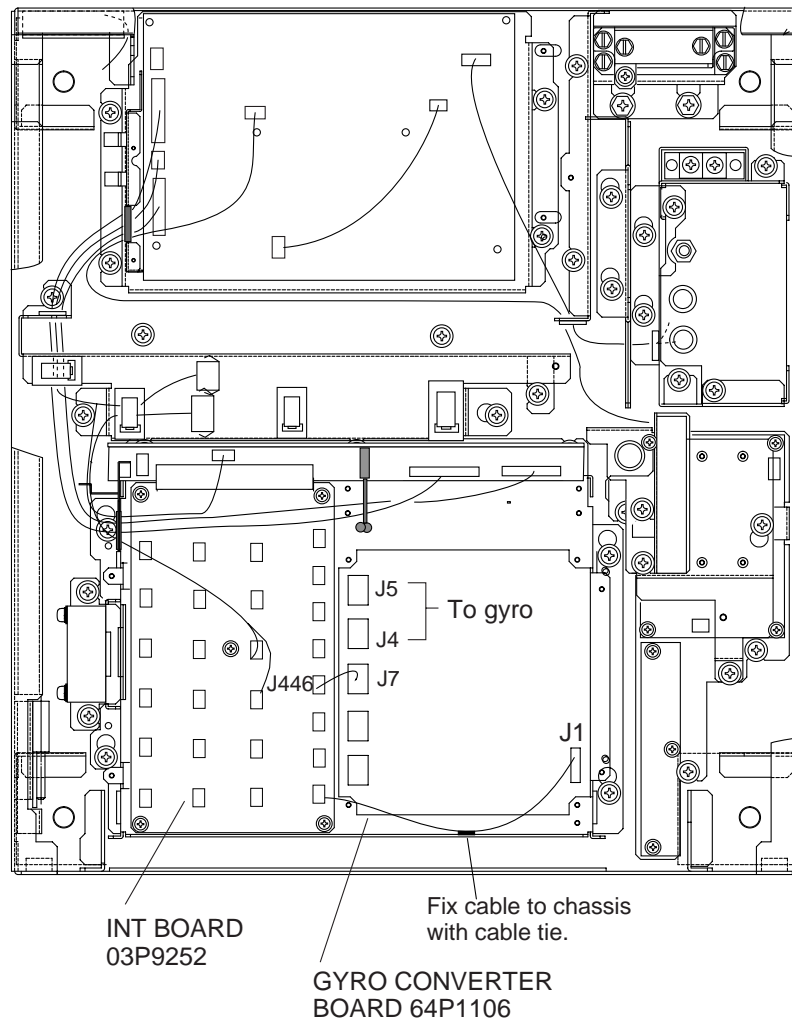

Figure 4-2 Display unit, inside view

- 5) Confirm gyrocompass specifications and set up the DIP switches and jumper wires on the GYRO CONVERTER Board according to gyrocompass connected:
- Setting jumper wires and DIP switches by gyrocompass specifications: page 4-3
 - Setting jumper wires and DIP switches by make and model of gyrocompass: page 4-5
 - Location of jumper wires and DIP switches: page 4-6
- 6) Solder the gyrocompass cable to the VH connector assemblies (supplied).
- 7) Attach instruction label (supplied) to the shield cover for the INT and GYRO CONVERTER boards.
- 8) Close the display unit.
- 9) Turn the power off and on to reset the CPU.

Connection of external power supply

An external power supply is necessary when the repeater signal is step-by-step type and the step voltage is below 20V or output voltage is less than 5 W.

1. Cut jumper wire JP1 on the GYRO CONVERTER Board when an external power supply is used.
2. Connect gyro cable and power cable as shown below.

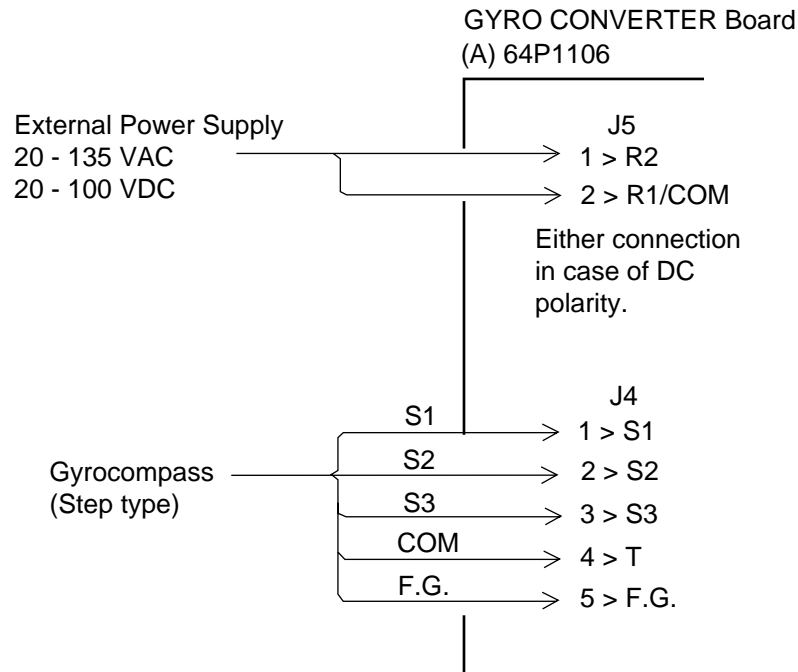

Figure 4-3 Connection of external power supply to GYRO CONVERTER Board

DIP switch, jumper wire settings

Default setting

The default setting of all DIP switches is off and all jumpers wire are set to “#1.” (Note that jumper wire JP1 is set at #1, #2, and #3.) In those settings the gyrocompass having the following characteristics can be directly connected; modification of the GYRO CONVERTER Board is not necessary.

AC synchronous signal: 50/60 Hz
Rotor voltage: 60 V to 135 V AC
Stator voltage: 60 V to 135 V AC
Gear ratio: 360x
Supply voltage: 30 V to 135 V AC

If the specifications of the gyrocompass differ from those mentioned above, change jumper wire and DIP switches settings on the GYRO CONVERTER Board. Settings may be changed according to gyrocompass specifications or make and model of gyrocompass (see page 4-5). For the location of DIP switches and jumper wires, see page 4-6.

Setting method 1: by gyrocompass specifications

1) Gyrocompass type

Gyrocompass type	SW 1-4	SW 1-5	SW 1-6	JP1
AC synchronous	OFF	OFF	OFF	#1, #2, #3
DC synchronous	OFF	OFF	OFF	#2, #3, #4
DC step	ON	OFF	OFF	#4, #5, #6
Full-wave pulsating current	OFF	ON	OFF	#4, #5, #6
Half-wave pulsating current	ON	ON	OFF	#4, #5, #6

2) Frequency

Frequency	SW 1-7	SW 1-8	Remarks
50/60Hz	OFF	OFF	AC synchronous pulsating current
400Hz	ON	OFF	AC synchronous pulsating current
500Hz	OFF	ON	AC synchronous pulsating current
DC	ON	ON	DC synchronous DC step

3) Rotor voltage (between R1 & R2)

Rotor voltage	SW 2-1	JP3
20V to 45V AC	ON	#2
30V to 70V AC	OFF	#2
40V to 90V AC	ON	#1
60V to 135V AC	OFF	#1

4) Stator voltage (between S1 and S2)

Stator voltage	SW 2-2	SW 2-3	JP2
20V to 45V AC, or 20V to 60V DC	ON	OFF	#2
20V to 45V AC, or 20V to 60V DC	OFF	OFF	#2
40V to 90V AC	ON	OFF	#1
60V to 135V AC	OFF	OFF	#1

5) Ratio

Ratio	SW1-1	SW 1-2	SW1-3
360x	OFF	OFF	OFF
180x	ON	OFF	OFF
90X	OFF	ON	OFF
36X	ON	ON	OFF

6) Supply voltage

Supply voltage	JP4	JP5
20V to 45V AC, or 20V to 60V DC	#2	#2
30V to 135V AC, or 40V to 100V DC	#1	#1

7) AD-10 format data Tx interval

Select data transmitting interval for ports 1 to 6 by jumper wires JP6 and JP7.

Note: The Tx interval is available in 25 msec or 200 msec. 25 msec is for radar; 200 msec is for all other equipment.

8) NMEA-0183 Tx interval

Tx interval	SW2-4
2 seconds	ON
1 second	OFF

Setting method 2: by make and model of gyrocompass

Maker	Models	Specification	SW 1-1	SW 1-2	SW 1-3	SW 1-4	SW 1-5	SW 1-6	SW 1-7	SW 1-8	SW 2-1	SW 2-2	SW 2-3	JP1	JP2	JP3	JP4	JP5
FURUNO	GY-700	DC step 100V 180x 5-wire, open collector	ON	OFF	OFF	ON	OFF	OFF	ON	ON	-	OFF	OFF	#4, #5,#6	#2	-	#1	#1
Anschutz	Standard 2,3	AC synchronous 50/60Hz Rotor voltage: 50/60V Stator voltage: 22V 360x	OFF	OFF	OFF	OFF	OFF	OFF	OFF	OFF	OFF	ON	OFF	#1, #2,#3	#2	#2	#1	#1
	Standard 4,6	AC synchronous 50/60Hz Rotor voltage: 50/60V Stator voltage: 90V 360x	OFF	OFF	OFF	OFF	OFF	OFF	OFF	OFF	OFF	OFF	OFF	#1, #2,#3	#2	#1	#1	#1
Yokogawa Navtec (Plait type)	C-1/1A/2/3 A-55, B-55	AC synchronous 50/60Hz Rotor voltage: 50/60V Stator voltage: 22V 360x	OFF	OFF	OFF	OFF	OFF	OFF	OFF	OFF	OFF	ON	OFF	#1, #2,#3	#2	#2	#1	#1
	CMZ-100/200/ C-JR,D-1Z/1/3 IPS-2/3	AC synchronous 50/60Hz Rotor voltage: 100V Stator voltage: 90V 360x	OFF	OFF	OFF	OFF	OFF	OFF	OFF	OFF	OFF	OFF	OFF	#1, #2,#3	#1	#1	#1	#1
	CMZ-300X/500	AC synchronous 50/60Hz Rotor voltage: 100V Stator voltage: 90V 90x	OFF	OFF	OFF	OFF	OFF	OFF	ON	ON	-	ON	OFF	Re- move	#2	-	Set by power supply.	
Plait	NAVGAT II/III	AC synchronous 50/60Hz Rotor voltage: 50/60V Stator voltage: 68V 360x	OFF	OFF	OFF	OFF	OFF	OFF	OFF	OFF	OFF	OFF	OFF	#1, #2,#3	#2	#2	#1	#1
Tokimec (Sperry type)	ES-1/2/11 GLT-101/102/- 103/106K/107	AC synchronous 50/60Hz Rotor voltage: 100/110V Stator voltage: 90V 36x	ON	ON	OFF	OFF	OFF	OFF	OFF	OFF	OFF	OFF	OFF	#1, #2,#3	#1	#1	#1	#1
	ES-11A/110 TG-200 PR222R PR237L/H GM 11	AC synchronous 50/60Hz Rotor voltage: 100/110V Stator voltage: 22V 90x	OFF	ON	OFF	OFF	OFF	OFF	OFF	OFF	OFF	OFF	OFF	#1, #2,#3	#1	#1	#1	#1
	MK-14 MOD-1/2/T NK-EN,NK-E1	DC step 70V 180x COM(+), 3-wire(-)	ON	OFF	OFF	ON	OFF	OFF	ON	ON	-	OFF	OFF	#4, #5,#6	#2	-	#1	#1
	SR-130/140	DC step 70V 180x 5-wire, open collector	ON	OFF	OFF	ON	OFF	OFF	ON	ON	-	OFF	OFF	#4, #5,#6	#2	-	#1	#1
	TG-100/5000 PR-357/130/1- 40, ES17 GLT-201/202/- 203	DC step 70V 180x COM(+), 3-wire(-)	ON	OFF	OFF	ON	OFF	OFF	ON	ON	-	ON	OFF	#4, #5,#6	#2	-	#1	#1
	TG-6000	DC step 24V 180x COM(-), 3-wire(+)	ON	OFF	OFF	ON	OFF	OFF	ON	ON	OFF	OFF	OFF	#4, #5,#6	#2	-	#2	#2
	SR-120,ES-16 MK-20	DC step 35V 180x COM(+), 3-wire(-)	ON	OFF	OFF	ON	OFF	OFF	ON	ON	-	ON	OFF	#4, #5,#6	#2	-	#2	#2
Kawasaki	GX-81	AC synchronous 50/60Hz Rotor voltage: 100V Stator voltage: 90V 90x	OFF	ON	OFF	OFF	OFF	OFF	OFF	OFF	-	OFF	OFF	#1, #2,#3	#1	#1	#1	#1
Armabrown	MK-10,MKL-1 SERIES1351, MOD-4	DC step 50V 180x COM(+), 3-wire(-)	ON	OFF	OFF	ON	OFF	OFF	ON	ON	OFF	OFF	OFF	#4, #5,#6	#2	-	#1	#1
Robertson	SKR-80	DC step 35V 180x COM(-), 3-wire(+)	ON	OFF	OFF	ON	OFF	OFF	ON	ON	-	ON	OFF	#4, #5,#6	#2	-	#2	#2

Location of DIP switches, jumper wires on the GYRO CONVERTER Board

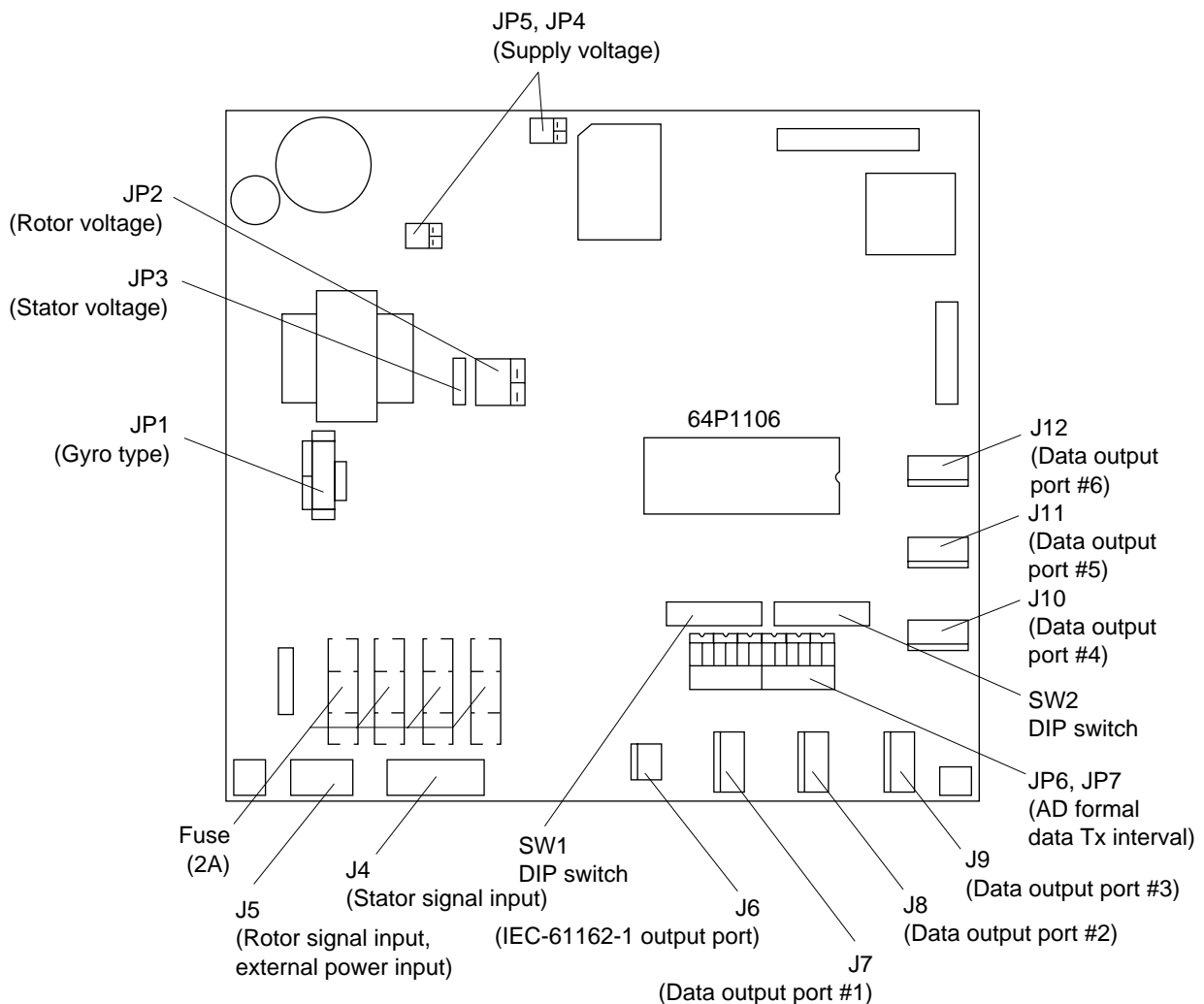

Figure 4-4 GYRO CONVERTER Board

Setting the heading readout on the radar display

Confirm that the gyrocompass is giving a reliable readout. Then, set the heading readout on the radar display with the gyrocompass readout as follows:

1. Press [RADAR MENU] to display the FUNCTIONS 1 menu.
2. Press the [0] key twice to display the FUNCTIONS 3 menu.
3. Press the [9] key to select the GYRO SETTING option.
4. Rotate the EBL control to align the radar's HDG readout with the gyrocompass.
5. Press [ENTER] to conclude the setting.

4.2 ARP Board ARP-26

The ARP Board ARP-26, which provides ARPA functions, is an optional circuit board which is accommodated in the display unit of the FR-2105 series radar.

Necessary Parts: ARP-26-2E (008-485-500)

Name	Type	Qty	Code no.
ARP board	18P9002B	1	008-473-650

Installation of the ARP board

1. Remove the bottom cover of the display unit by unfastening four screws.
2. Set the ARP Board in the center slot of the PCB card case.

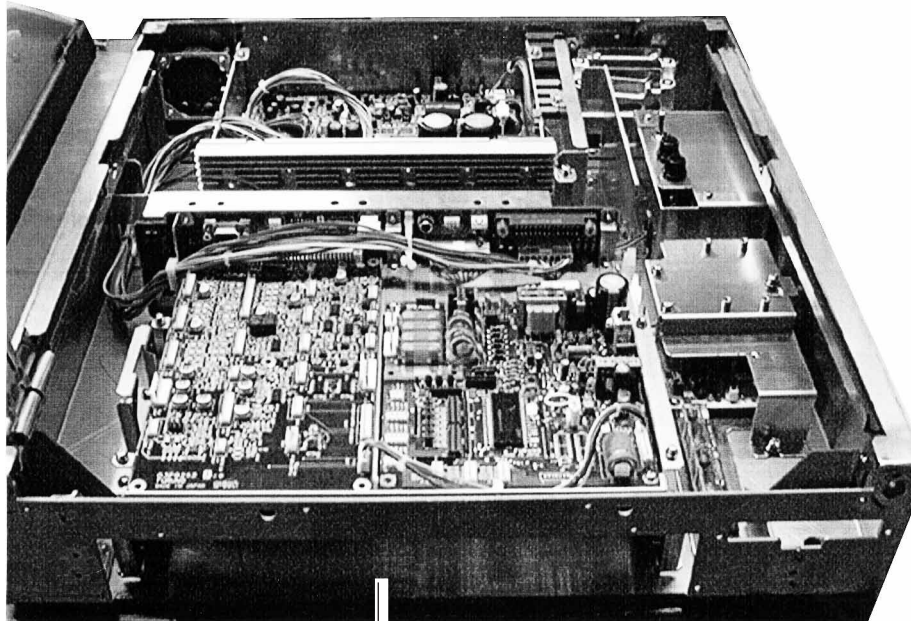

PCB card case
Top: RP Board (Option)
Middle: ARP Board (Option)
Bottom: SPU Board

Figure 4-5 Display pedestal inside view

3. Adjust the ARP referring to the procedure on the next page.

ARP board adjustment

1. Turn the GAIN, A/C SEA and A/C RAIN controls fully counterclockwise, and then transmit on the 12 nm range.
2. Connect a digital multimeter between TP7(+) and TP6(-) on the ARP Board.

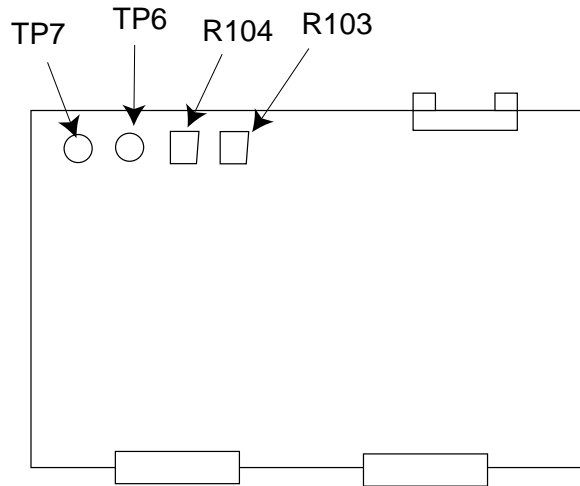

Figure 4-6 ARP Board (18P9002B)

3. Adjust R104 on the ARP Board so the multimeter reads between 0.09 and 0.14 VDC.
4. Set controls and switches as below.
GAIN: fully clockwise (max.)
Interference rejector: OFF
Range: 24 nm
Echo stretch: OFF
5. Press [RADAR MENU] [0] [0] [0] [0] open the INITIAL SETTING3 menu.
6. Set the VIDEO SIG field to DIGITAL and press [ENTER].
7. Adjust R103 on the ARP Board so noise just appears on the display.

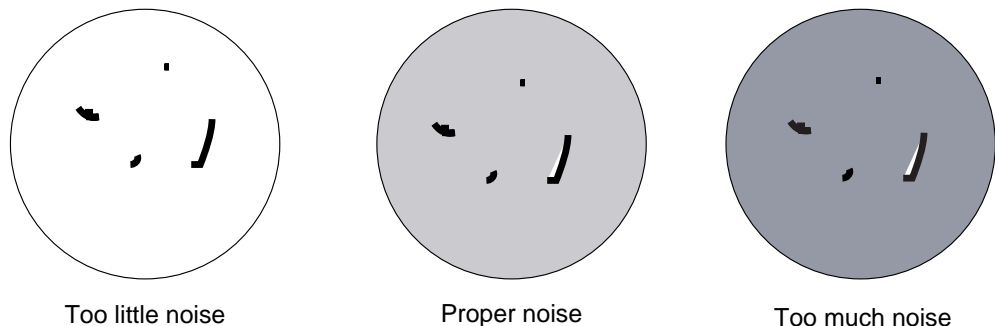

Figure 4-7 How to adjust noise

8. Set VIDEO SIG to ANALOG and press [ENTER].

Final check

Connect a gyrocompass and a log to the radar and place the radar under transmit state. Confirm that LEDs CR9, CR10, CR11, CR12, CR15 and CR16 on the ARP Board are off. If ship's speed is zero, or other signal is not being input, corresponding LED will light.

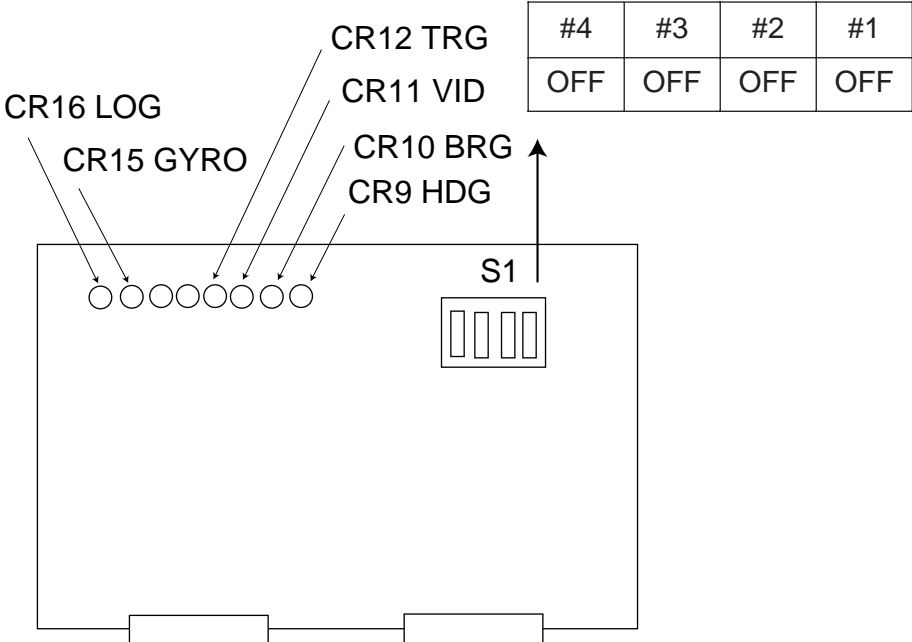

Figure 4-8 ARP Board ARP-26

4.3 RP Board RP-26

The RP Board RP-26, which provides video plotter functions, consists of a circuit board and a card drive both of which are accommodated in the display unit of the FR-2105 series radar.

Table top/console type

Necessary Parts: RP-26-T-2E (008-485-520)

Name	Type	Qty	Code no.
RP board	14P0298	1	008-487-640
Card case assy.	—	1	—
Panhead screw B	M4x8 C2700W	4	000-881-445
Panhead screw B	M3x8 C2700W	2	000-881-404
Panhead screw A	M2.6x5 C2700W	2	000-800-973
Teethed lock washer (Outside teeth)	M4 C5191W	1	000-864-506
Cable assy.	HIF6-100D-A-A-52	1	000-137-553

1. Lift the monitor and fix it with the stay. Refer to Chapter 1 for instructions.
2. Remove the right arm cover from the control head.
3. Fasten the card case to the right arm cover as follows:
 - a) Fasten the ground wire with an M4x10 screw and washer (supplied) as shown below.
 - b) Fasten the arm cover to the card case with three M4x8 screws (supplied).

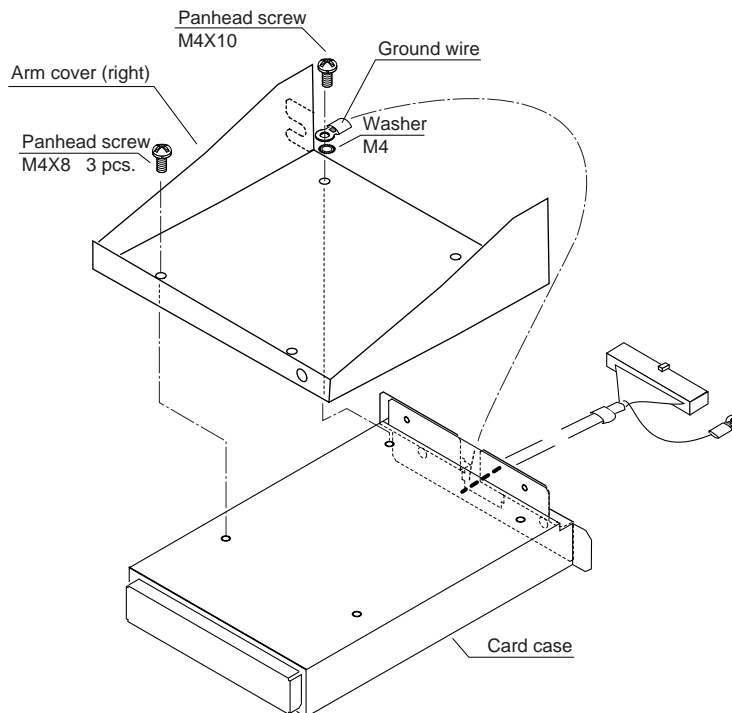

Figure 4-9 Fastening the card case to the right arm cover

4. Unfasten the front panel from the display pedestal.
5. Pass the connector from the card case through the hole in the display pedestal.

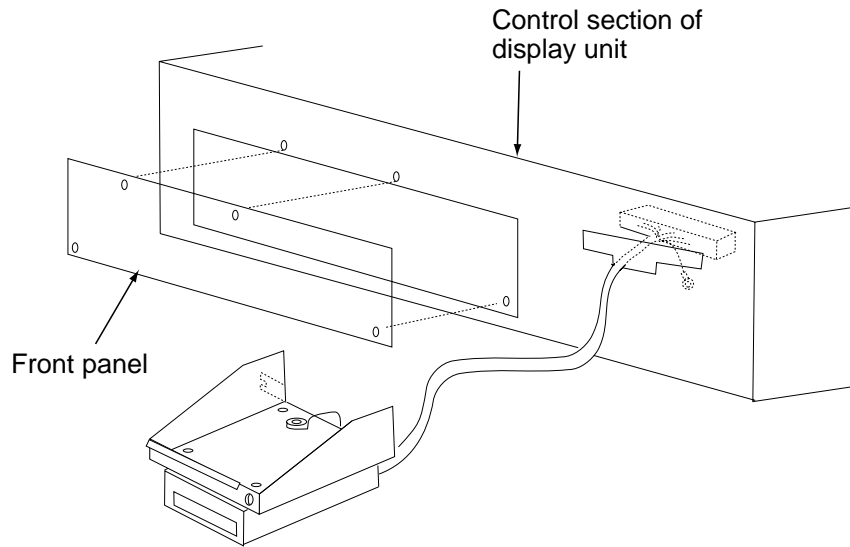
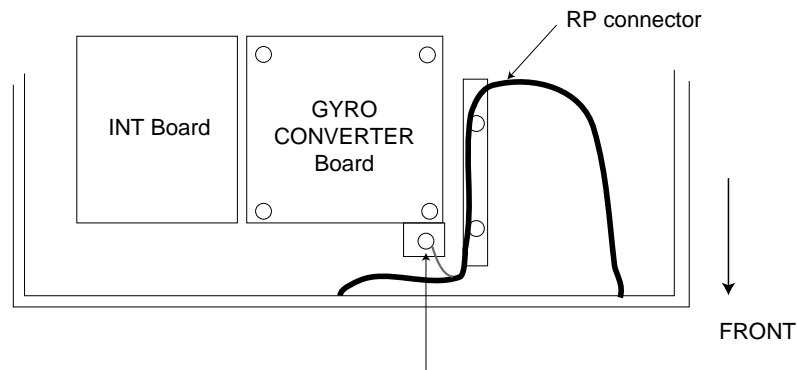

Figure 4-10 Display pedestal

6. Set the RP Board (14P0298) in the top slot of the pcb card case. See page 4-7 for the location of the pcb card case.
7. Run the connector from the card case in front of the GYRO CONVERTER Board.
8. Plug the connector in J1 on the RP Board.
9. Fasten the ground wire from the connector at the location shown below.



Fasten ground wire from connector to this screw.

(TOP VIEW)

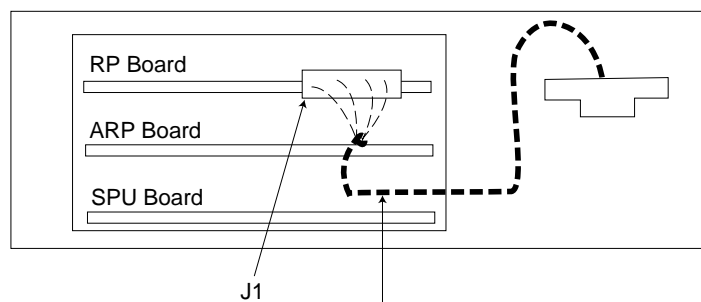

Route cable between ARP and SPU Boards.

(FRONT VIEW)

Figure 4-11 Display pedestal, top view

10. Fasten the front panel on the display pedestal.
11. Retract the stay to close the display unit.
12. Fasten the right arm cover.

Separate type control head

Necessary parts: RP-26-Z-2E (Code no. 008-491-400)

Name	Type	Qty	Code No.
Card Case Assy.	—	1	—
RP Board	14P0298	1	008-487-640
Pan Head Screw B	M4x8 C2700W	1	000-881-445
Pan Head Screw B	M3x8 C2700W	2	000-881-404
Pan Head Screw A	M2.6x5 C2700W	2	000-800-973

1. Lift the monitor. See Chapter 1 for instructions.
2. Fasten the mounting base with one M4 x 8 screw as below.

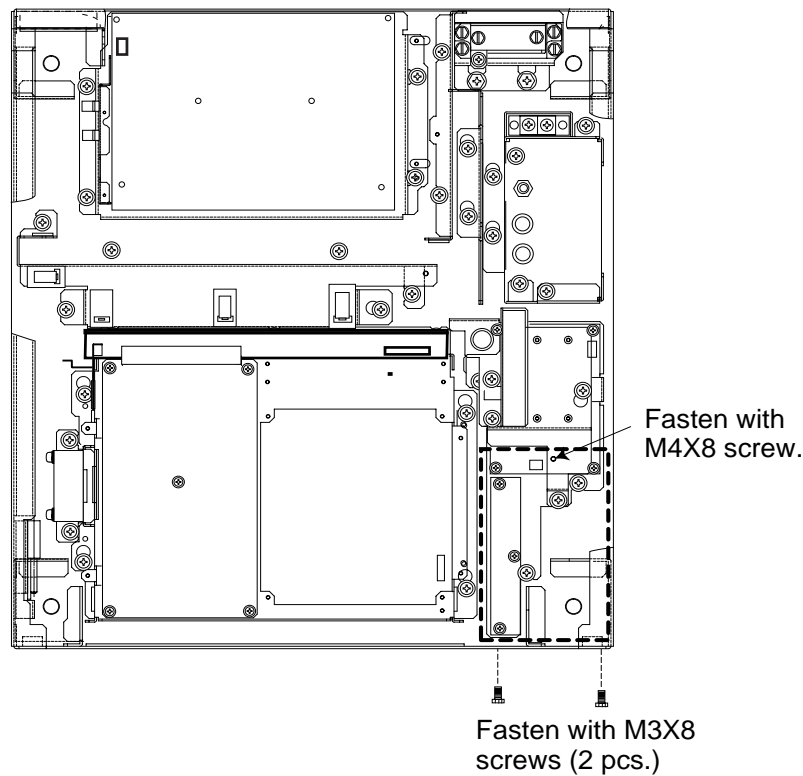

Figure 4-12 Display unit, inside view

3. Fix the mounting base to front panel with two M3 x 8 screws.
4. Set the M-card case lid to the hole in the front panel and fix with two M2.6 x 5 screws.

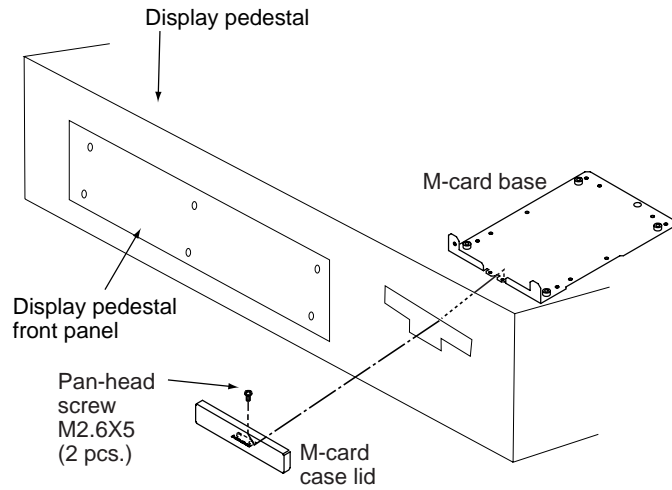
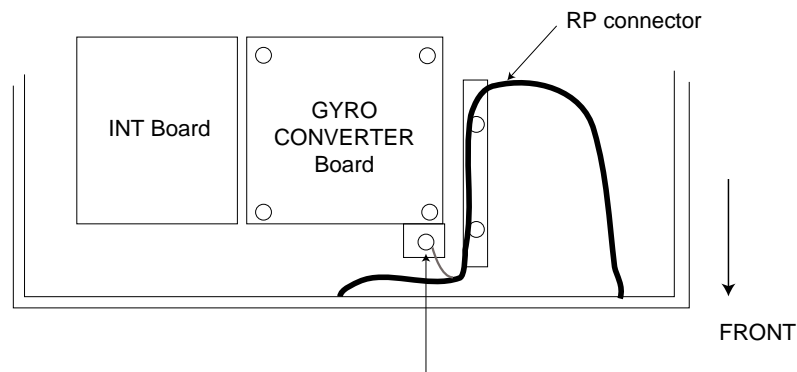

Figure 4-13 Display pedestal, front view

5. Loosen six screws to remove the front panel on the display pedestal.
6. Set the RP Board (14P0298) in the top slot of the pcb card case.
7. Run the connector from the card case in front of the GYRO CONVERTER Board.
8. Plug the connector in J1 on the RP Board.
9. Fasten the ground wire from the connector at the location shown below.



Fasten ground wire from connector to this screw.

(TOP VIEW)

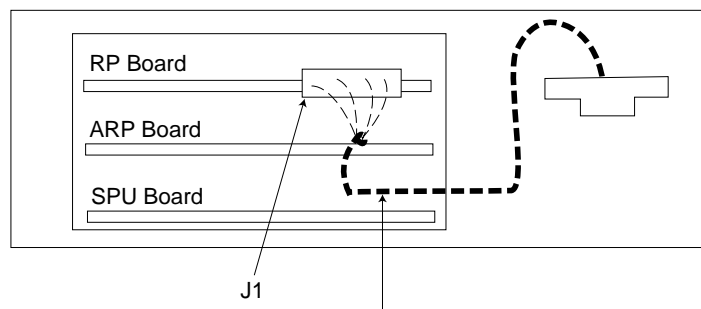

Route cable between ARP and SPU Boards.

(FRONT VIEW)

Figure 4-14 Display pedestal, top view

10. Fasten the front panel of the display pedestal.
11. Fasten the ground wire to the location shown in Figure 4-14.
12. Close the monitor.

4.4 Performance Monitor PM-30

Necessary parts: PM-30 and OP03-150 (Code no. 008-485-490)

Name	Type	Qty	Code No.
PM-IN Board	03P9225	1	008-487-620
Pan-head Screw B	M3X8 C2700W	3	000-881-404
Connector Assy.	VH3P-L300-AA	2	000-141-014

1. Lift the monitor. See Chapter 1 for instructions.
2. Fasten the PM Board 03P9225 to the location shown below with three screws (M3 x 8).

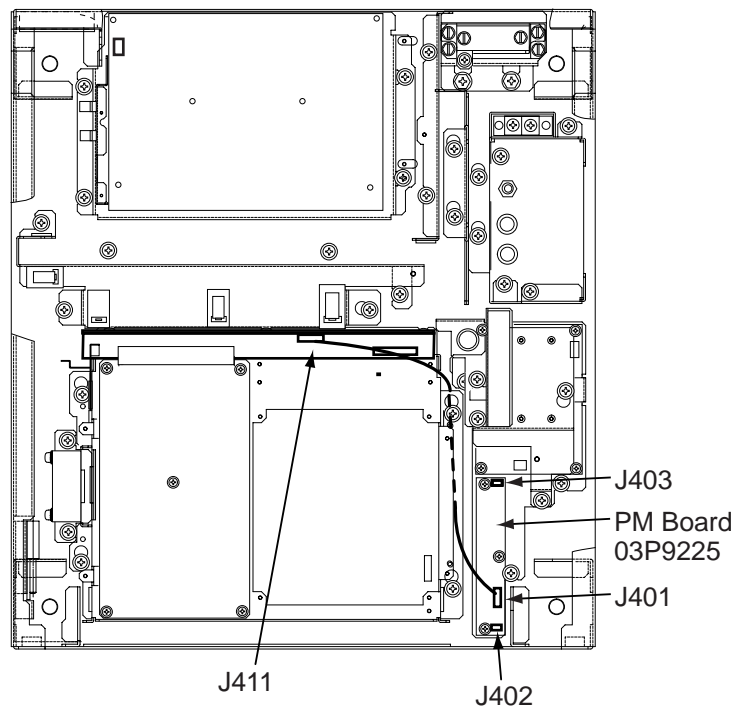

Figure 4-15 Display unit, inside view

3. Connect the connector P401 coming from J411 to J401 on the PM Board.
4. Connect two connector assemblies (VH3P-L300-AA) to J402 and J403.
5. Solder the other end of these connector assemblies with external cables, one from ship's mains and one from the PM-30.
6. Close the monitor.

4.5 Alarm Kit

Necessary parts: OP03-156 (Code no. 008-500-650)

The alarm kit mainly consists of a circuit board and connection cables, and provides alarm output to ship's bridge alarm system.

Contents of Alarm Kit OP03-156

Name	Type	Code No.	Qty
ALARM Board	03P9262	008-500-680	1
NH Connector Assy.	03-1990(9-9P)	008-500-700	1
NH Connector Assy.	03-1991(3P)	008-500-710	4
Cable Band	HP-3N	000-570-001	1
Cable Tie	CV-100	000-570-322	3
Pan-head Screw B	M3X8 C2700W	000-881-404	4
Pan-head Screw B	M4X12 C2700W	000-881-447	1

Procedure

Refer to the figure below for parts locations.

1. Raise the monitor and fix it with the stay. (See page 1-5 for instructions.)
2. Unfasten four screws to dismount the shield cover for the INT Board.
3. Fasten the ALARM Board to the display unit with four pan-head screws (M3X8, supplied).
4. Connect the NH connector (9-9P, supplied) between J471 on the ALARM Board and J451 (EXT-BUZ) on the INT Board, passing it through the cable band and binding it with existing cable tie.
5. Fasten the cable band (supplied) with a pan-head screw (M4X12, supplied) and attach two cable ties (CV-100, supplied).
6. Connect an NH connector (3P, supplied) to each of J472, J473, J474 and J475 on the ALARM Board.
7. Route the NH connectors along the cables ties and pass them through the cable clamp. Fasten the shield cover removed at step 1.
8. Close the INT board cover.
9. Close the monitor.
10. Connect NH connectors to ship's bridge alarm system:
 - J472: ARPA guard zone; target alarm
 - J473: SYSTEM FAILURE (HP, BP, TRIG, VIDEO, GYRO, AZI)
 - J474: ARPA CPA/TCPA
 - J475: Spare

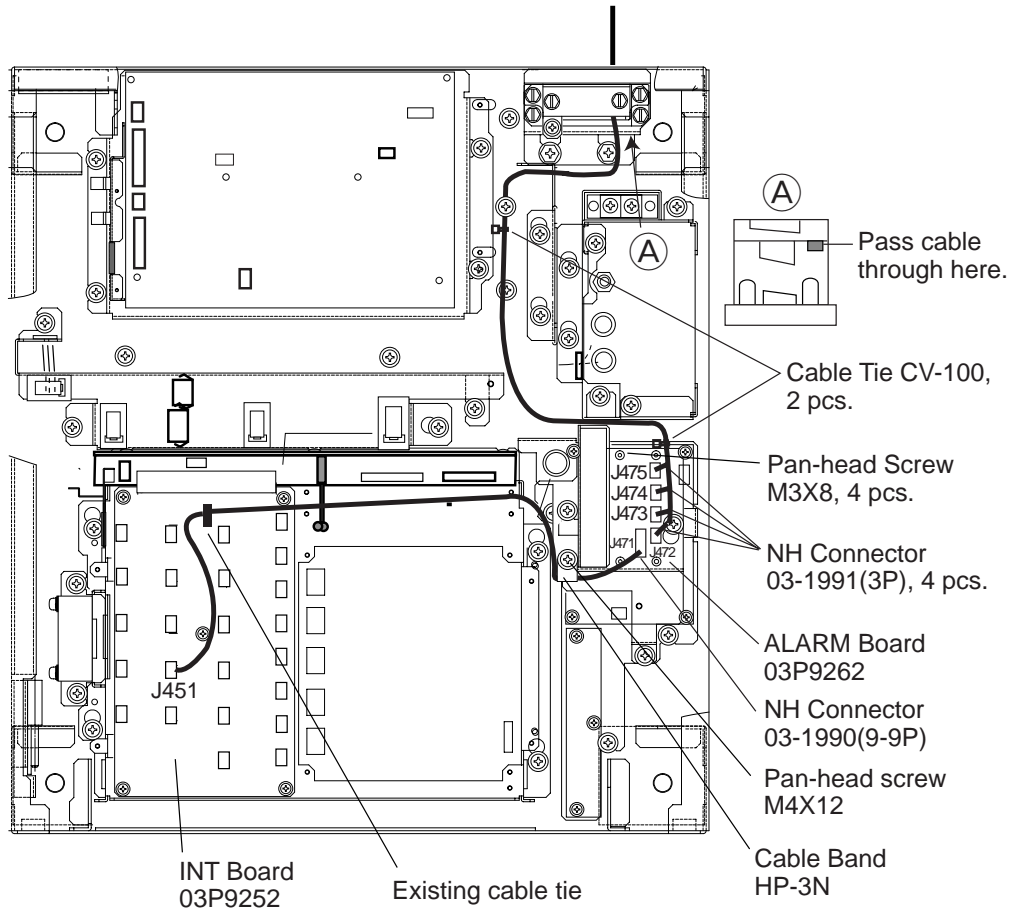
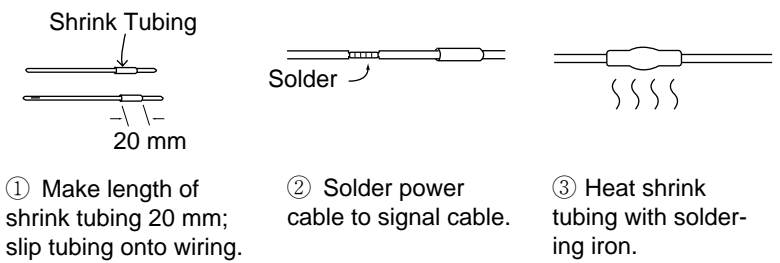

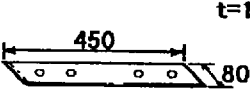
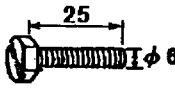

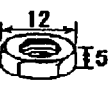
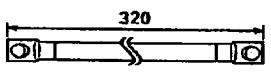
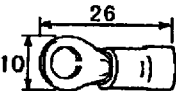
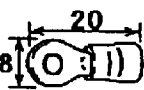

Figure 4-16 Display unit, inside view

HOW TO INSULATE THE POWER CABLE



FURUNO

CODE NO.	008-461-750	03EU-X-9406 -5 1/2
TYPE	CP03-14601	

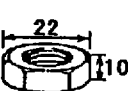
工事材料表 INSTALLATION MATERIALS		FR/FAR-2855/2150 FR-2160DS/2155 FR-2165DS レーダー RADAR			
番号 NO.	名称 NAME	略図 OUTLINE	型名/規格 DESCRIPTIONS	数量 Q'TY	用途/備考 REMARKS
1	防蝕ゴム CORROSION-PROOF RUBBER MAT		03-029-0301-2	2	
			CODE NO. 100-091-112		
2	六角ボルト HEX. BOLT		M6X25 SUS304	1	
			CODE NO. 000-862-180		
3	シールワッシャー SEAL WASHER		03-001-3002-0	4	
			CODE NO. 300-130-020		
4	バネ座金 SPRING WASHER		M6 SUS304	1	
			CODE NO. 000-864-260		
5	六角ナット 1種 HEX. NUT		M6 SUS304	1	
			CODE NO. 000-863-109		
6	アース線 GROUNDING WIRE		RW-4747-1 03S4747	1	
			CODE NO. 000-566-000		
7	圧着端子 CRIMP-ON LUG		FV5. 5-4	2	
			CODE NO. 000-538-123		
8	圧着端子 CRIMP-ON LUG		FV1. 25-4	18	
			CODE NO. 000-538-114		
9	圧着端子 CRIMP-ON LUG		FV1. 25-M3 7A	26	
			CODE NO. 000-538-110		
10	六角ナット 1種 HEX. NUT		M12 SUS304	4	
			CODE NO. 000-863-112		

DWG. NO.





C3407-M01- C

FURUNO ELECTRIC CO., LTD

(略図の寸法は、参考値です。 DIMENSIONS IN DRAWING FOR REFERENCE ONLY.)

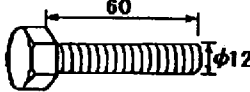
FURUNO

CODE NO.	008-461-750	03EU-X-9406 -5 2/2
TYPE	CP03-14601	

工事材料表 INSTALLATION MATERIALS		FR/FAR-2855/2150 レーダー FR-2160DS/2155 FR-2165DS RADAR			
番号 NO.	名称 NAME	略図 OUTLINE	型名/規格 DESCRIPTIONS	数量 Q'TY	用途/備考 REMARKS
11	六角ボルト (全長) HEX. BOLT		M12X60 SUS304	4	
	CODE NO.		000-862-191		
12	スプリング座金 SPRING WASHER		M12 SUS304	4	
	CODE NO.		000-864-263		
13	フラット座金 FLAT WASHER		M12 SUS304	4	
	CODE NO.		000-864-132		
14	圧着端子 CRIMP-ON LUG		FVD1. 25-3	1	
	CODE NO.		000-116-634		
15	フラット座金 FLAT WASHER		M6 SUS304	3	
	CODE NO.		000-864-129		

DWG NO.

C3407-M02- C

FURUNO ELECTRIC CO., LTD

(略図の寸法は、参考値です。 DIMENSIONS IN DRAWING FOR REFERENCE ONLY.)

FURUNO

CODE NO.	008-485-460	03FS-X-9401 -2 1/2
TYPE	CP03-19103	

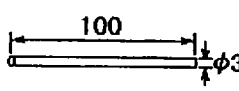
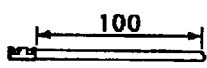
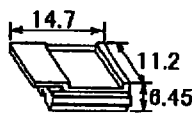
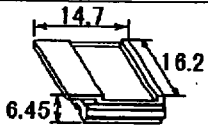
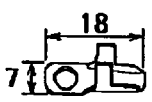
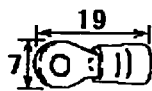
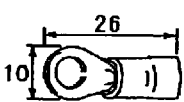
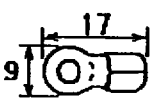
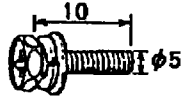
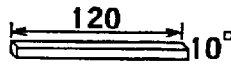
工事材料表 INSTALLATION MATERIALS		FR-2115/2125/2125W 船舶用レーダ FR-2155/2135S FR-2135S/W/2165DS MARINE RADAR			
番号 NO.	名称 NAME	略図 OUTLINE	型名/規格 DESCRIPTIONS	数量 Q'TY	用途/備考 REMARKS
1	スチューブ F(Z) HEAT-SHRINK TUBE		3X0.25 加 *0.10M* CODE NO. 000-105-874	2	
2	NHコネクタ アセンブリ NH CONNECTOR ASSY.		AWG24 *0.1M* CODE NO. 000-132-342	20	
3	コネクタ CONNECTOR		H3P-SHF-AA CODE NO. 000-505-596	2	
4	コネクタ CONNECTOR		H5P-SHF-AA CODE NO. 000-505-598	2	
5	特殊ラグ LUG		7*14 ス CODE NO. 000-536-100	2	
6	圧着端子 CRIMP-ON LUG		FY1.25-M3 7* CODE NO. 000-538-110	5	
7	圧着端子 CRIMP-ON LUG		FV5.5-4 CODE NO. 000-538-123	2	
8	圧着端子 CRIMP-ON LUG		8NK4 CODE NO. 000-538-180	2	
9	六角ボルト (ワッシャーヘッド) HEX. BOLT (WASHER HEAD)		M5X10 SUS304 CODE NO. 000-802-288	2	
10	シールドフォーム SHIELD FOAM		71TS-10-10*0.12M* CODE NO. 000-808-456	4	

DWG NO. C3464-M01-D

FURUNO ELECTRIC CO., LTD

(略図の寸法は、参考値です。 DIMENSIONS IN DRAWING FOR REFERENCE ONLY.)

FURUNO

CODE NO.	008-485-460	03FS-X-9401 -2 2/2
TYPE	CP03-19103	

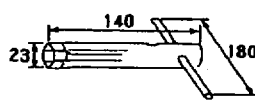
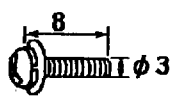
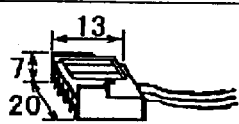
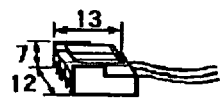
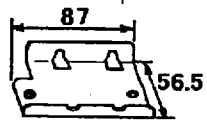
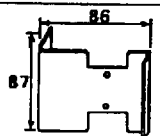
工事材料表 INSTALLATION MATERIALS		FR-2115/2125/2125W 船舶用レーダ FR-2155/2135S FR-2135SW/2165DS MARINE RADAR			
番号 NO.	名称 NAME	略図 OUTLINE	型名/規格 DESCRIPTIONS	数量 Q'TY	用途/備考 REMARKS
11	パイプボックス パイプ PS PIPE BOX SPANNER		PS0017	1	
			CODE NO.		
12	ワッシャー ビス B WASHER HEAD SCREW		M3X8 C2700 MBN12	2	
			CODE NO.		
13	VH コネクタ 組品 VH CONNECTOR ASSY.		03-1737(5P)	1	
			CODE NO.		
14	VH コネクタ 組品 VH CONNECTOR ASSY.		03-1738(3P)	1	
			CODE NO.		
15	下 クランプ 前板 LOWER CLAMP FRONT PLATE		03-144-1425-1	1	
			CODE NO.		
16	下 クランプ 後板 LOWER CLAMP REAR PLATE		03-144-1426-0	1	
			CODE NO.		

DWG NO. C3464-M02-D

FURUNO ELECTRIC CO., LTD

(略図の寸法は、参考値です。 DIMENSIONS IN DRAWING FOR REFERENCE ONLY.)

FURUNO

CODE NO.	008-452-790	03EP-X-9409 -2 1/1
TYPE	CP03-13916	

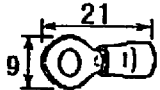
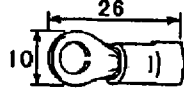
工事材料表 INSTALLATION MATERIALS		FR/FAR-2855 FR-2150/2160DS/2155 FR-2165DS		船舶用レーダ MARINE RADAR		
番号 NO.	名称 NAME	略図 OUTLINE	型名/規格 DESCRIPTIONS		数量 Q'TY	用途/備考 REMARKS
1	圧着端子 CRIMP-ON LUG		FV1. 25-M3 7φ		9	
			CODE NO.	000-538-110		
2	圧着端子 CRIMP-ON LUG		FV2-4A 7φ		11	
			CODE NO.	000-538-118		
3	圧着端子 CRIMP-ON LUG		FV5. 5-4		5	
			CODE NO.	000-538-123		



DWG NO. C3390-M03- C

FURUNO ELECTRIC CO., LTD

(略図の寸法は、参考値です。 DIMENSIONS IN DRAWING FOR REFERENCE ONLY.)

FURUNO

CODE NO.	008-452-540	03EP-X-9405 -2 1/1
TYPE	CP03-13907	

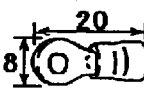
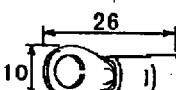
工事材料表 INSTALLATION MATERIALS		FR/FAR-2800 シリーズ FR-2100 シリーズ		レーダー RADAR	
番号 NO.	名称 NAME	略図 OUTLINE	型名/規格 DESCRIPTIONS	数量 Q'TY	用途/備考 REMARKS
1	特殊 LUG		7744 ス	2	
			CODE NO.		
2	圧着端子 CRIMP-ON LUG		FV1. 25-M3 7A	16	
			CODE NO.		
3	圧着端子 CRIMP-ON LUG		FV1. 25-4	11	
			CODE NO.		
4	圧着端子 CRIMP-ON LUG		FV5. 5-4	19	
			CODE NO.		

DWG NO.



C3387-M01- C

FURUNO ELECTRIC CO., LTD

(略図の寸法は、参考値です。 DIMENSIONS IN DRAWING FOR REFERENCE ONLY.)

FURUNO

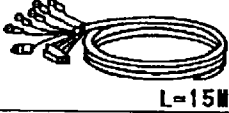
CODE NO.		03FT-X-9404 -0
TYPE		1/1

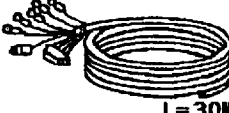
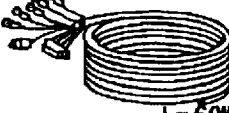
工事材料表 INSTALLATION MATERIALS		FR-2165DS 船舶用レーダ MARINE RADAR			
番号 NO.	名称 NAME	略図 OUTLINE	型名/規格 DESCRIPTIONS	数量 Q'TY	用途/備考 REMARKS
1	信号ケーブル組品 SIGNAL CABLE ASSY.	 L=15M	S03-84-15	1	選択 TO BE SELECTED
			CODE NO. 008-492-850		
2	信号ケーブル組品 SIGNAL CABLE ASSY.	 L=20M	S03-84-20	1	選択 TO BE SELECTED
			CODE NO. 008-492-860		
3	信号ケーブル組品 SIGNAL CABLE ASSY.	 L=30M	S03-84-30	1	選択 TO BE SELECTED
			CODE NO. 008-492-870		
4	信号ケーブル組品 SIGNAL CABLE ASSY.	 L=60M	S03-84-60	1	選択 TO BE SELECTED
			CODE NO. 008-492-880		





DWG NO. C3468-M01- A

FURUNO ELECTRIC CO., LTD

(略図の寸法は、参考値です。 DIMENSIONS IN DRAWING FOR REFERENCE ONLY.)

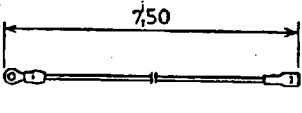
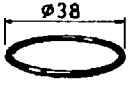
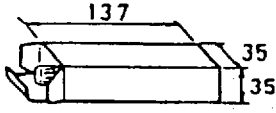
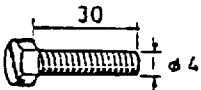
FURUNO

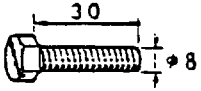
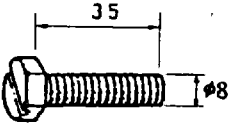
CODE NO.	008-324-110	03AX-X-9403-
TYPE	XN4A	

工事材料表 INSTALLATION MATERIALS		レーダ-空中線組立材料 RADAR ANTENNA ASSEMBLING MATERIALS			
番号 No.	名称 NAME	略図 OUTLINE	型名 / 規格 DESCRIPTIONS	数量 Q'TY	用途 / 備考 REMARKS
1	線材加工品 LEAD WIRE ASSY.		FR700/1000/1200 XN-4A 2.4M アンテナ用 CODE NO. 008-162-720	1	
2	Oリング O-RING		AS568-125 1115-70 CODE NO. 000-851-840	2	
3	スリーホント ADHESIVE		1211 50G CODE NO. 000-854-118	1	
4	六角ボルトスリ割付 HEX. BOLT (SLOTTED HEAD)		M4X30 SUS 304 CODE NO. 000-862-116	2	
5	ミカキ平座金 FLAT WASHER		M4 SUS304 CODE NO. 000-864-126	2	
6	ハネ座金 SPRING WASHER		M4 SUS304 CODE NO. 000-864-256	2	
7	六角ボルトスリ割付 HEX. BOLT (SLOTTED HEAD)		M8X30 SUS304 CODE NO. 000-862-151	4	
8	六角ボルトスリ割付 HEX. BOLT (SLOTTED HEAD)		M8X35 SUS304 CODE NO. 000-862-153	4	
9	ミカキ平座金 FLAT WASHER		M8 SUS304 CODE NO. 000-864-130	12	
10	ハネ座金 SPRING WASHER		M8 SUS304 CODE NO. 000-864-262	8	

(略図の寸法は、参考値です。)

図番 (1/2)
DWG. NO. C3041-M03-A

FURUNO

CODE NO.	008-324-110	03AX-X-9404-
TYPE	XN4A	

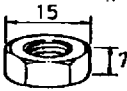
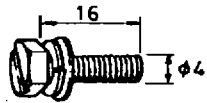
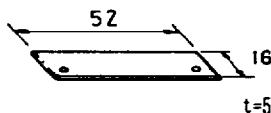
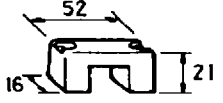



工事材料表 INSTALLATION MATERIALS		レーダー空中線組立材料 RADAR ANTENNA ASSEMBLING MATERIALS			
番号 No	名称 NAME	略図 OUTLINE	型名 / 規格 DESCRIPTIONS	数量 Q'TY	用途 / 備考 REMARKS
11	六角ナット1種 HEX. NUT		M8 SUS304	4	
			CODE NO. 000-863-110		
12	六角ビス入り割付 WASHER HEAD		M4X16 SUS304	8	
			CODE NO. 000-882-042		
13	導波管間座 WAVEGUIDE PACKING		03-003-4003-0	1	
			CODE NO. 300-340-030		
14	導波管押え(1)E型 WAVEGUIDE CLAMP (1) E-TYPE		RSB-2006-1	1	
			CODE NO. 360-220-061		
			CODE NO.		
			CODE NO.		
			CODE NO.		
			CODE NO.		
			CODE NO.		
			CODE NO.		

(略図の寸法は、参考値です。)
DIMENSIONS IN DRAWING FOR REFERENCE ONLY.

図番 (2/2)
DWG. NO. C3041-M04-B

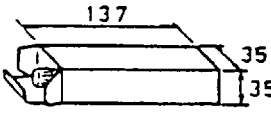
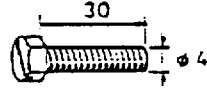
FURUNO

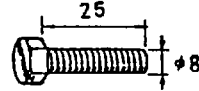
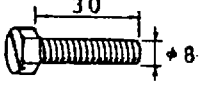
CODE NO	008-444-860	03AX-X-9405-
TYPE	XN5A	

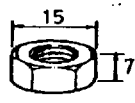
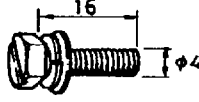

工事材料表 INSTALLATION MATERIALS		レーダー空中線組立材料 RADAR ANTENNA ASSEMBLING MATERIALS			
番号 No	名称 NAME	略図 OUTLINE	型名 / 規格 DESCRIPTIONS	数量 Q'TY	用途 / 備考 REMARKS
1	スリーホント ADHESIVE		1211 50G	1	
			CODE NO 000-854-118		
2	六角ボルトスリ割付 (SLOTTED HEAD)		M4X30 SUS 304	2	
			CODE NO 000-862-116		
3	ミカキ平座金 FLAT WASHER		M4 SUS304	2	
			CODE NO 000-864-126		
4	ハネ座金 SPRING WASHER		M4 SUS304	2	
			CODE NO 000-864-256		
5	六角ボルトスリ割付 (SLOTTED HEAD)		M8X25 SUS304	4	
			CODE NO 000-862-149		
6	六角ボルトスリ割付 (SLOTTED HEAD)		M8X30 SUS304	4	
			CODE NO 000-862-151		
7	ミカキ平座金 FLAT WASHER		M8 SUS304	12	
			CODE NO 000-864-130		
8	ハネ座金 SPRING WASHER		M8 SUS304	8	
			CODE NO 000-864-262		
9	六角ナット1種 HEX. NUT		M8 SUS304	4	
			CODE NO 000-863-110		
10	六角ヒムズリ割付 WASHER HEAD)		M4X16 SUS304	8	
			CODE NO 000-882-042		

(略図の寸法は、参考値です。)

図番 (1/1)
DWG. NO. C3041-M05-A

FURUNO

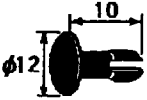
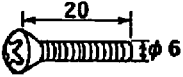
CODE NO.	008-478-830	03FS-X-9501 -1 1/1
TYPE	FP03-06201	

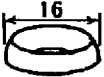
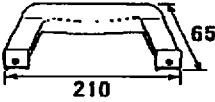
付属品表 ACCESSORIES		FR-2115/2125/2155 FR-2125W/2135S FR-2135SW		船舶用レーダ MARINE RADAR	
番号 NO.	名称 NAME	略図 OUTLINE	型名/規格 DESCRIPTIONS	数量 Q'TY	用途/備考 REMARKS
1	プラスチック PLASTIC RIVET		KB-1330 樹脂リベット	4	
			CODE NO. 000-570-276		
2	丸皿小ねじ OVAL COUNTERSUNK HEAD SCREW		M6x20 C2700W 樹脂リベット	4	
			CODE NO. 000-861-475		
3	波座金 WAVE WASHER		WW-6 SUS	4	
			CODE NO. 000-864-350		
4	ロゼット座金 ROSETTE WASHER		M6 C2700W 樹脂リベット	4	
			CODE NO. 000-864-910		
5	取手 HANDLE		14-002-1125-2	2	
			CODE NO. 840-211-252		

DWG NO. C3464-F01-C

FURUNO ELECTRIC CO., LTD

(略図の寸法は、参考値です。 DIMENSIONS IN DRAWING FOR REFERENCE ONLY.)

FURUNO

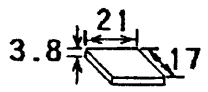
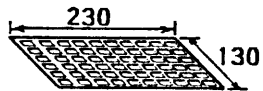
付属品表 ACCESSORIES		FR-2115/2125/2155 FR-2135S/2135SW 2165DS		船舶用レーダ MARINE RADAR	CODE NO. 008-485-480	03FS-X-9504 -3
					TYPE FP03-06502	1/1
番号 NO.	名称 NAME	略図 OUTLINE	型名/規格 DESCRIPTIONS	数量 Q'TY	用途/備考 REMARKS	
1	ユーザキーキャップ USER KEYCAP		03-144-1613-1	4		
			CODE NO. 100-263-831			
2	ユーザキーシート(E) USER KEYSHEET(E)		03-144-1655-1	1		
			CODE NO. 100-263-881			

DWG NO.
C3464-F04-D

FURUNO ELECTRIC CO., LTD

(略図の寸法は、参考値です。 DIMENSIONS IN DRAWING FOR REFERENCE ONLY.)

FURUNO

CODE NO.	008-490-970	03FS-X-9502 -2 1/1
TYPE	FP03-06503	

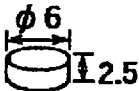
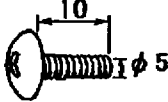
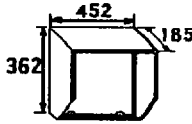
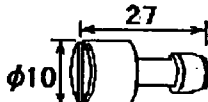
付属品表 ACCESSORIES		FR-2115/2125/2155 船舶用レーダ FR-2125W/2135S FR-2135SW MARINE RADAR			
番号 NO.	名称 NAME	略図 OUTLINE	型名/規格 DESCRIPTIONS	数量 Q'TY	用途/備考 REMARKS
1	Spacer SPACER		5X2.5	2	
			CODE NO. 000-808-429		
2	Screw SCREW		M5X10 C2700W	2	
			CODE NO. 000-808-430		
3	Hood HOOD		03-144-1335-0	1	
			CODE NO. 100-263-330		
4	Hood Retainer HOOD RETAINER		03-144-1336-0	2	
			CODE NO. 100-266-310		

DWG NO. C3464-F02- C

FURUNO ELECTRIC CO., LTD

(略図の寸法は、参考値です。 DIMENSIONS IN DRAWING FOR REFERENCE ONLY.)

FURUNO

CODE NO.	008-493-240	03FS-X-9505 -0 1/1
TYPE	FP03-06504	

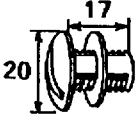
付属品表 ACCESSORIES		FR- 2115/2125/2125W/2135 S/2135SW/2155/2165DS 船舶用レーダー MARINE RADAR			
番号 NO.	名称 NAME	略図 OUTLINE	型名/規格 DESCRIPTIONS	数量 Q'TY	用途/備考 REMARKS
1	化粧キャップ COSMETIC CAP		CP-30-BC-10 CODE NO. 000-808-408	4	

DWG NO.
C3464-F05- A

FURUNO ELECTRIC CO., LTD

(略図の寸法は、参考値です。 DIMENSIONS IN DRAWING FOR REFERENCE ONLY.)

FURUNO

CODE NO.	008-424-380	03DZ-X-9303 -5
TYPE	SP03-09203	BOX NO. P

SHIP NO.		SPARE PARTS LIST FOR		U S E			SETS PER VESSEL
ITEM NO.	NAME OF PART	OUTLINE	DWG. NO. OR TYPE NO.	QUANTITY		REMARKS/CODE NO.	
				WORKING	SPARE		
				PER SET	PER VES		
1	カーボンブラシ CARBON BRUSH		T-A01297B	4		4 000-115-023	
MFR'S NAME		FURUNO ELECTRIC CO., LTD		DWG NO.		C3357-P03- G	1/1

(略図の寸法は、参考値です。 DIMENSIONS IN DRAWING FOR REFERENCE ONLY.)

4
3
2

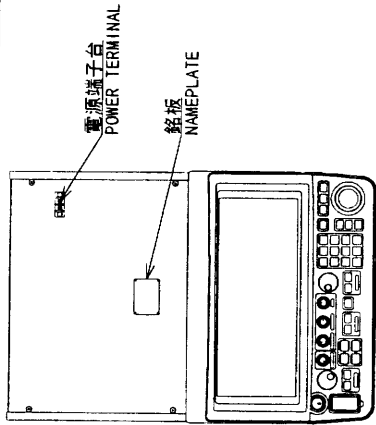

寸法区分 (mm)	DIMENSION	公差 (mm)	TOL.
L ≤ 50		±1.5	
50 < L ≤ 100		±2.5	
100 < L ≤ 500		±3	
500 < L ≤ 1000		±4	
1000 < L ≤ 2000		±5	

表 1
TABLE 1

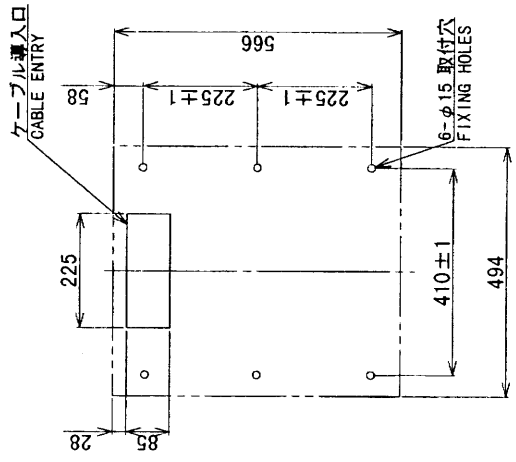
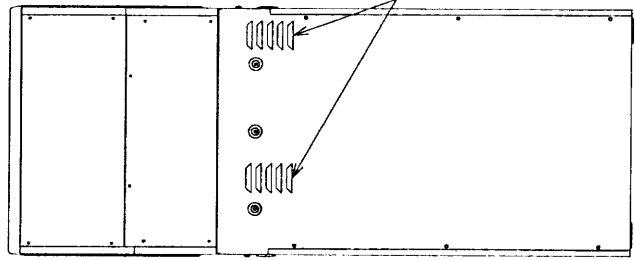
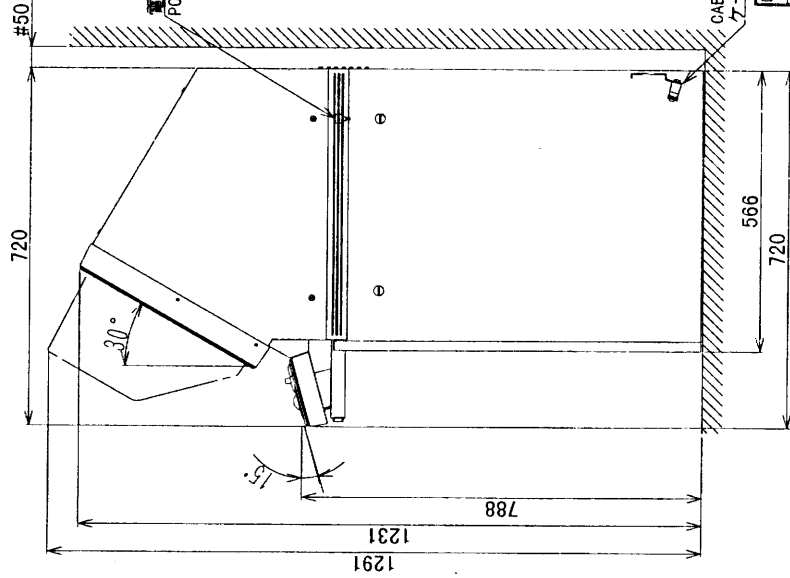
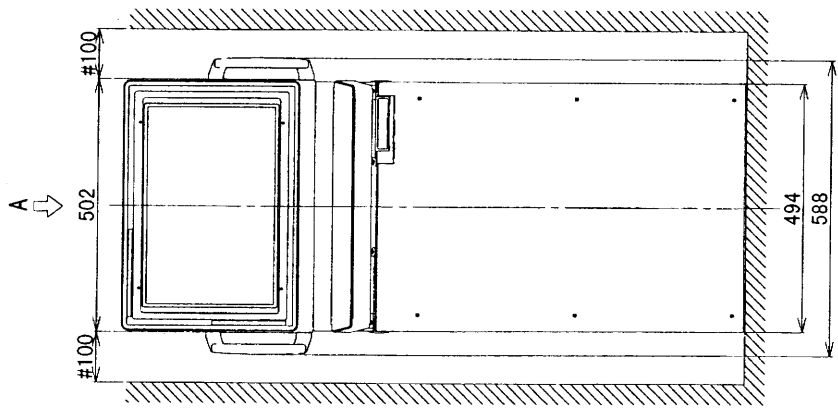
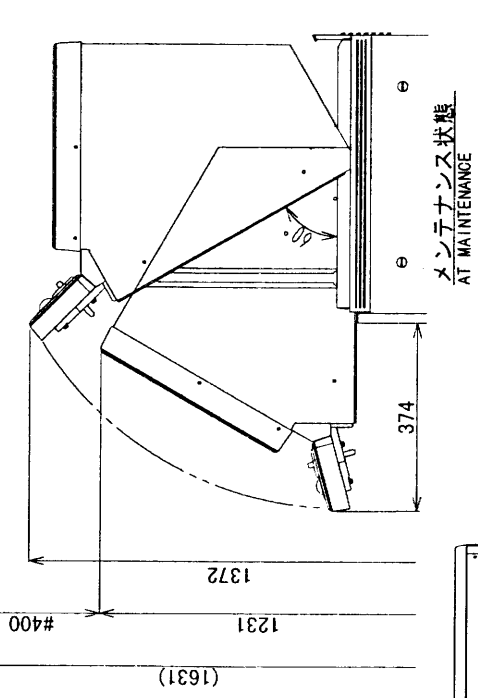

取付寸法図 (矢視A)
MOUNTING DIMENSIONS (VIEW A)

DRAWING NO.	C3464-G03-B	TITLE	RDP-124
DESIGNED BY	1299 Iwakura	名称	指示部 (コンソール型)
CHECKED BY	799 K. Kasai	外寸図	
APPROVED BY	799 K. Kasai	NAME	DISPLAY UNIT (CONSOLE TYPE)
SCALE	1/15	OTHERS	
DATE	FR-213	FIG. NO.	03-144-1800-04
SCALE	1/15	MASS	110 kg
DWG. No.	C3464-G03-B		

注 記 1) #印寸法は最小サービスペース寸法とする。
2) 指定外の寸法公差は、表 1 による。

NOTE 1. #: RECOMMENDED SERVICE CLEARANCE.
2. TABLE 1 INDICATES TOLERANCE OF DIMENSIONS.

FURUNO

2 3 4

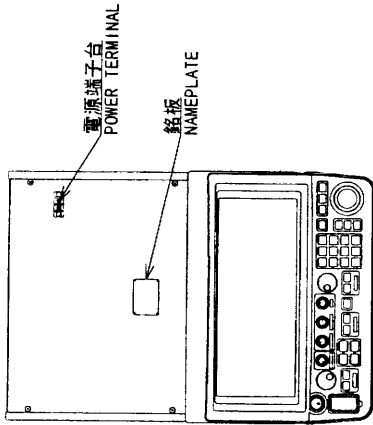

寸法区分 (mm)	DIMENSION	公差 (mm)	TOL.
L ≤ 50		±1.5	
50 < L ≤ 100		±2.5	
100 < L ≤ 500		±3	
500 < L ≤ 1000		±4	
1000 < L ≤ 2000		±5	

表 1
TABLE 1

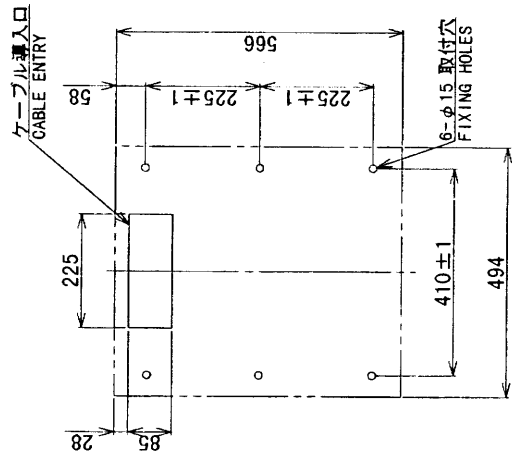
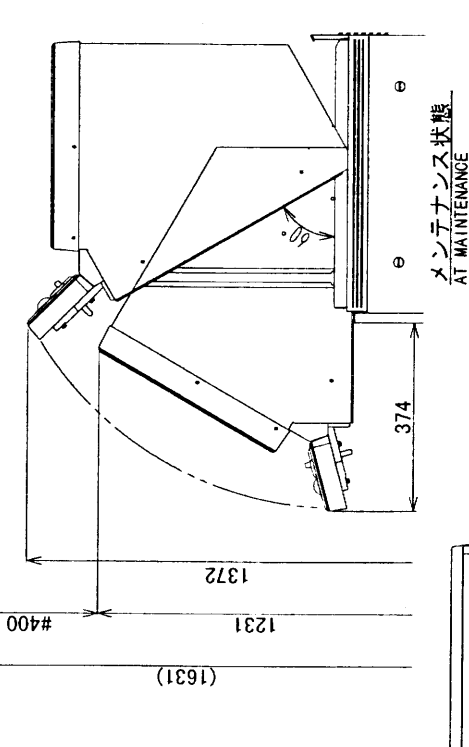
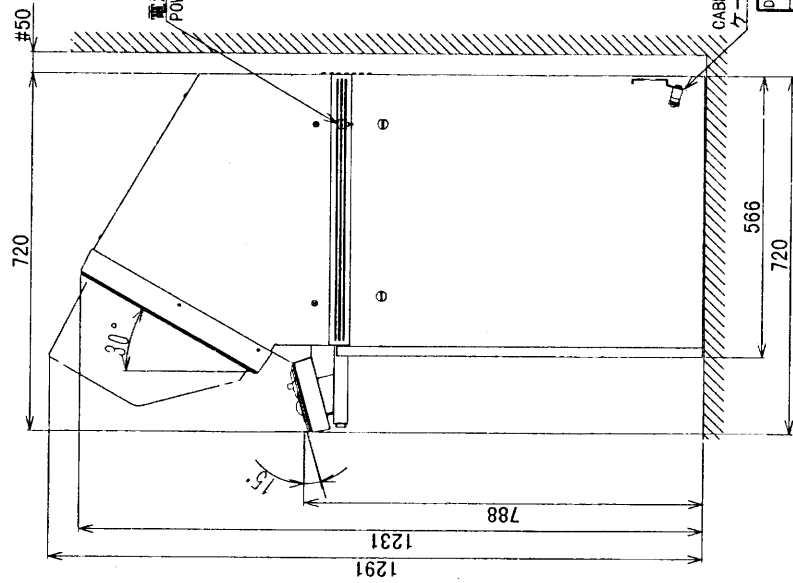
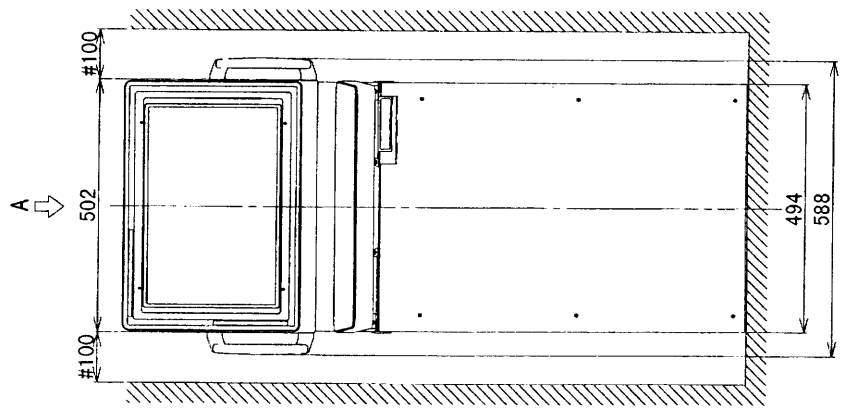

取付寸法図 (矢視A)
MOUNTING DIMENSIONS (VIEW A)

DRAWN Ishiguro 12777	TITLE RDP-124
CHECKED Takahashi 7777	名称 指示部 (コンソール型)
DESIGNED Kawamura 7777	外寸図
SCALE 1/15	NAME DISPLAY UNIT (CONSOLE TYPE)
OTHERS FR-2175	OUTLINE DRAWING
MASS 110 kg	03-144-1800-04
DWG. No. C3464-G03-B	

注 記 1) #印寸法は最小サービスクリアランスとする。
2) 指定外の寸法公差は、表 1 による。

NOTE 1. #: RECOMMENDED SERVICE CLEARANCE.

2. TABLE 1 INDICATES TOLERANCE OF DIMENSIONS.

FURUNO ELECTRIC CO., LTD.

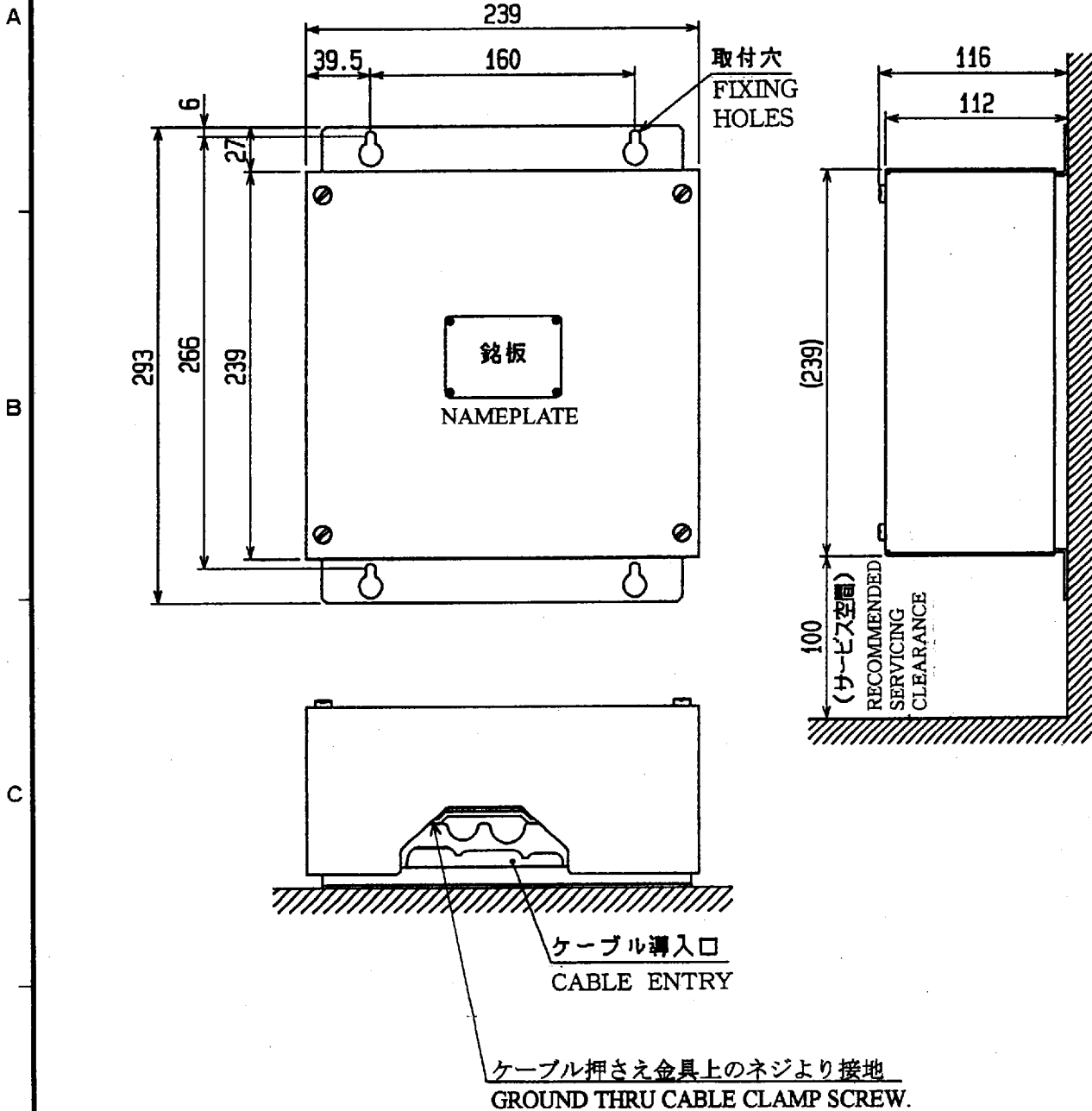

注 記：取付ネジは+トラスタッピンネジ呼び径5×20を使用のこと

NOTE: FIX THE UNIT BY USING FOUR TAPPING SCREWS (φ5×20).

DRAWN Aug 28 '98 T. YAMASAKI				TYPE PSU-004
CHECKED Apr 28 '98 K. Kusunoki				名称 電源制御部
APPROVED Apr 28 '98 K. Kusunoki				外寸図
SCALE 1 / 4	MASS 2.3 kg	APPLICABLE TO; (MODEL)	BLOCK NO.	NAME POWER SUPPLY UNIT
DWG NO. C3385-G02- C				OUTLINE DRAWING

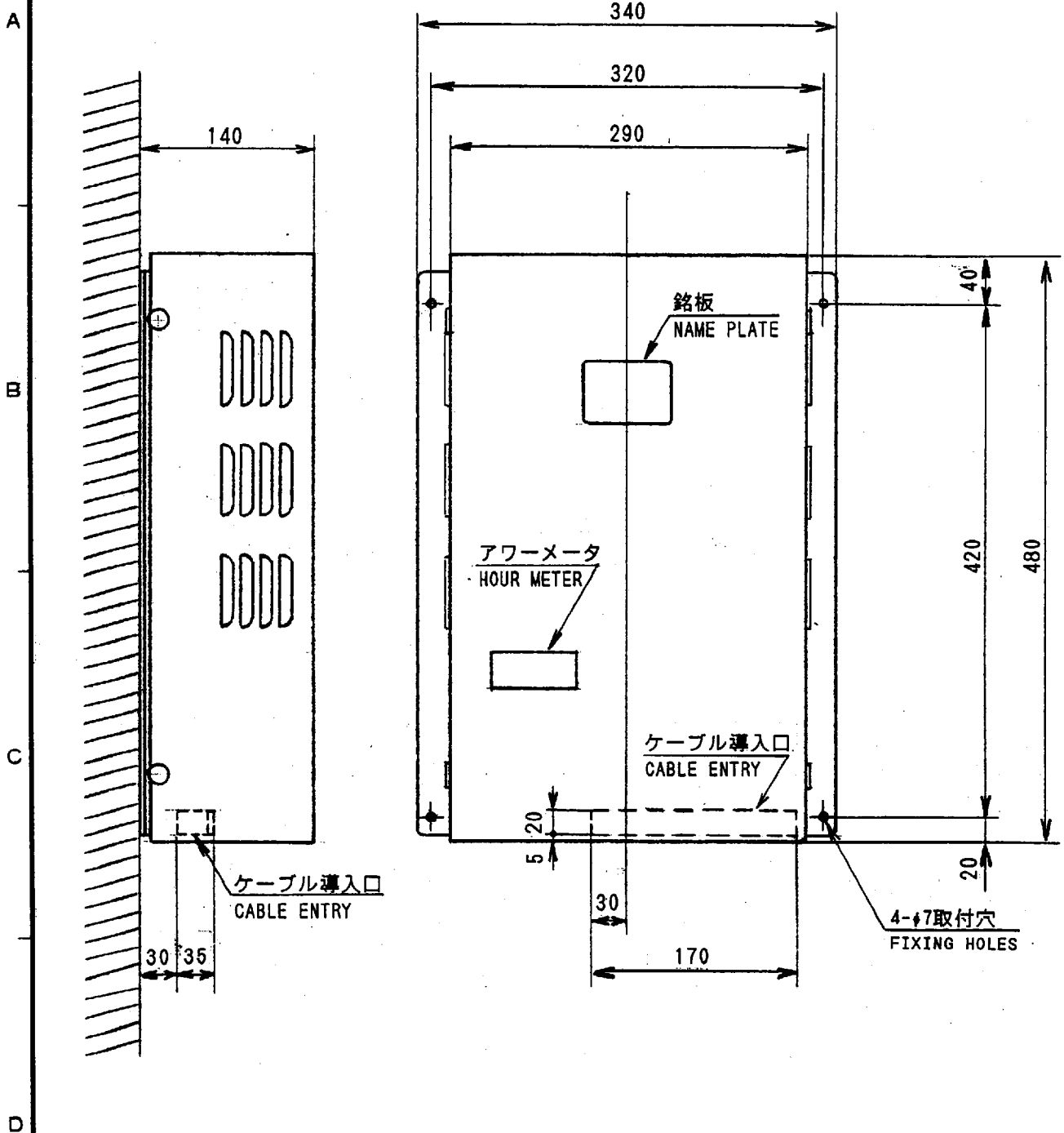

DRAWN Aug 28 '98 T. YAMASAKI			TYPB PSU-001/002
CHECKED Aug 28 '98 K. Kusunoki			名称 空中線電源部
APPROVED Aug 28 '98 K. Kusunoki			外寸図
SCALE 1 / 5	MASS 7 kg	APPLICABLE TO; (MODEL)	BLOCK NO. NAME POWER SUPPLY UNIT
DWG NO. C3353-G01- D			OUTLINE DRAWING

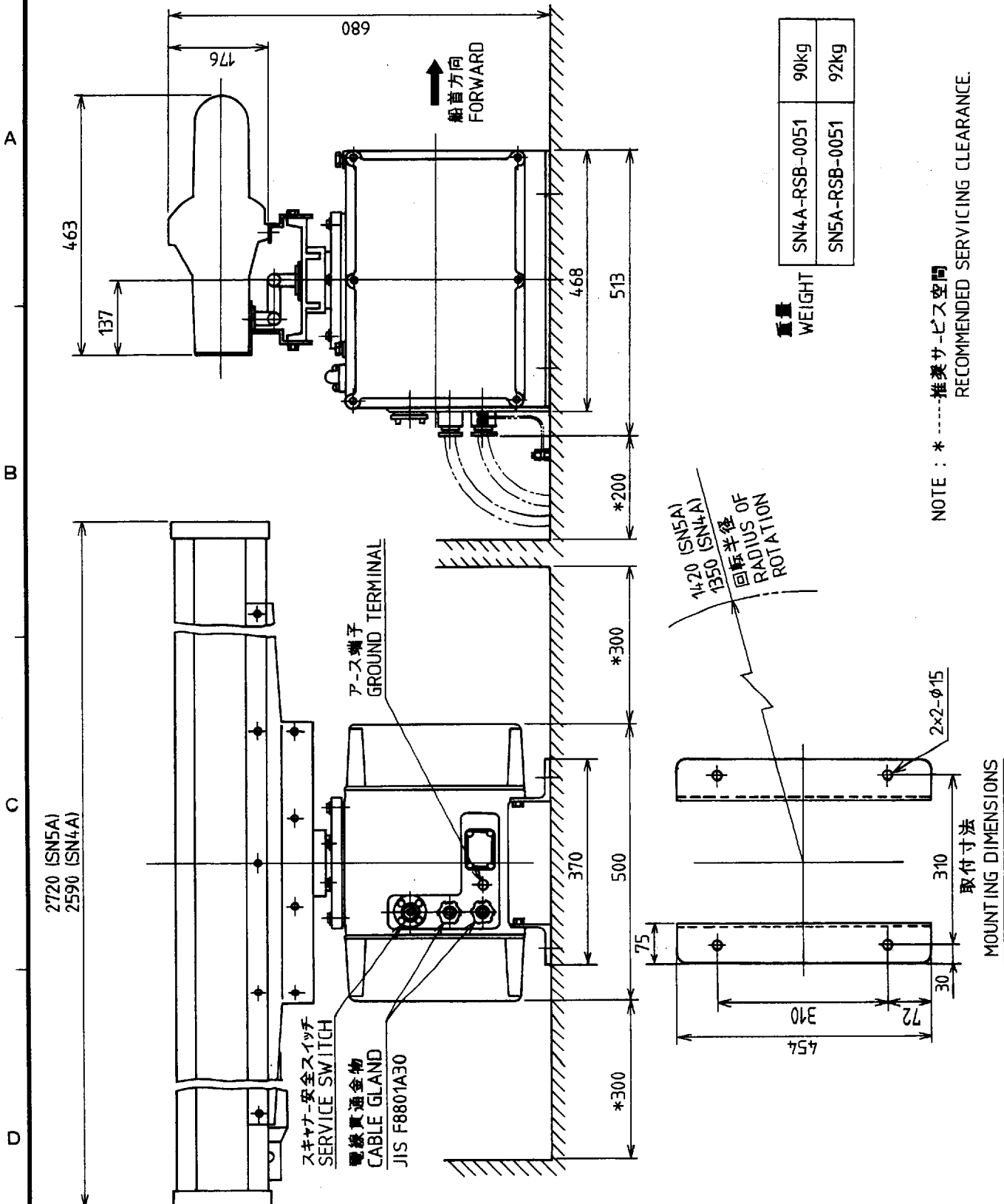

NOTE : *推奨サ-ビス空間
RECOMMENDED SERVICING CLEARANCE.

2720 (SN5A)
2590 (SN4A)

スキャナ-安全スイッチ
SERVICE SWITCH
電線貫通金物
CABLE GLAND
JIS F8801A30

1420 (SN5A)
1350 (SN4A)
回転半径
RADIUS OF
ROTATION

取付寸法
MOUNTING DIMENSIONS

FR-1460DS

品番 ITEM	品名 NAME	材質 MATERIAL	数量 Q'TY	図番 DWG.NO.	摘要 REMARKS
承認 APPROVED	JUN. 28 '91 T. NAKANO	三角法 THIRD ANGLE PROJECTION		名称 TITLE	SN4A/5A-RSB-0051 レーダ-空中線部外寸図 RADAR SCANNER UNIT
検図 CHECKED	JUN. 28 '91 N. SAITO	尺度 SCALE	1 / 10	製図 DRAWN	JUN. 28 '91 I. AMANO
重量 WEIGHT	kg	図番 DWG.NO.	C3357-G01-B		

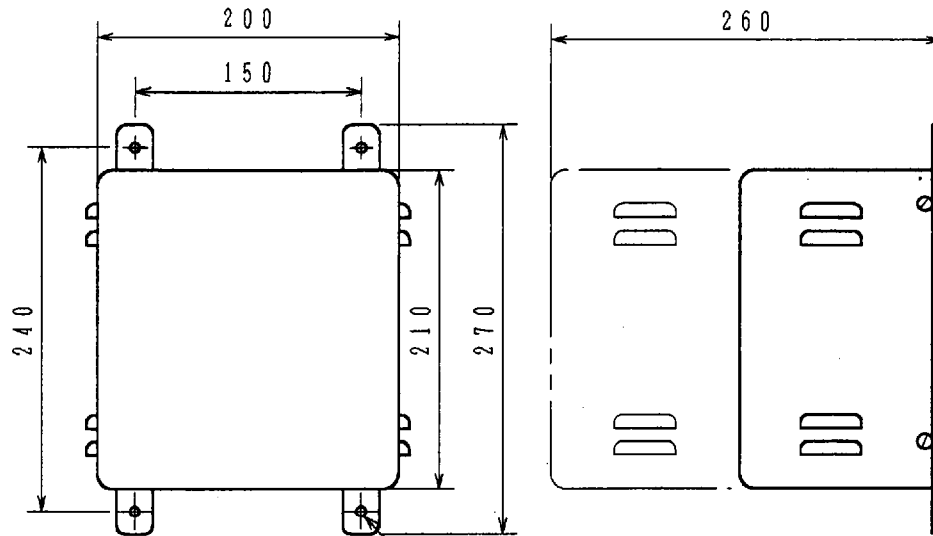

取付穴
4-7φ FIXING HOLES

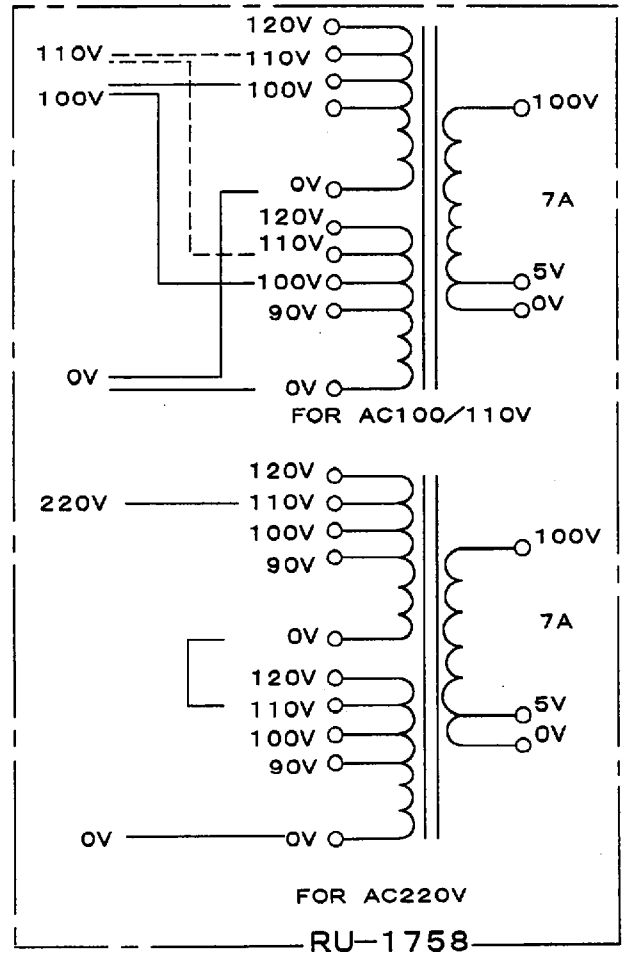
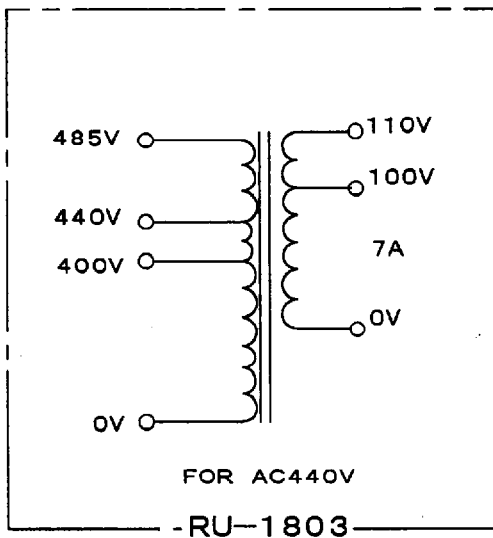
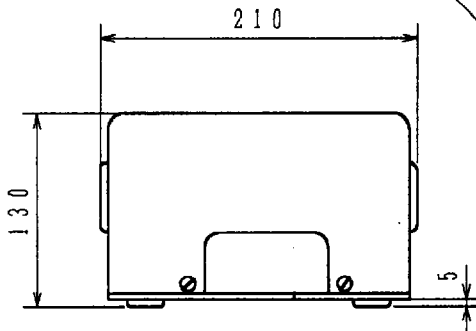

DRAWN June 17 '96 Y. EBISU		TITLE RU-1758/1803
CHECKED June 18 '96 K. Kusunoki		名称 トランスユニット
APPROVED June 18 '96 K. VTA		外寸図
SCALE 1/5 MASS 12 kg		NAME TRANSFORMER UNIT
DWG No. C3003-001-D		

A
B
C
D

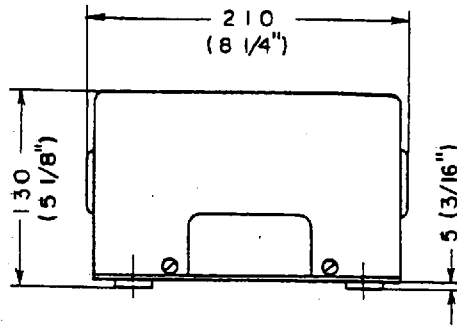
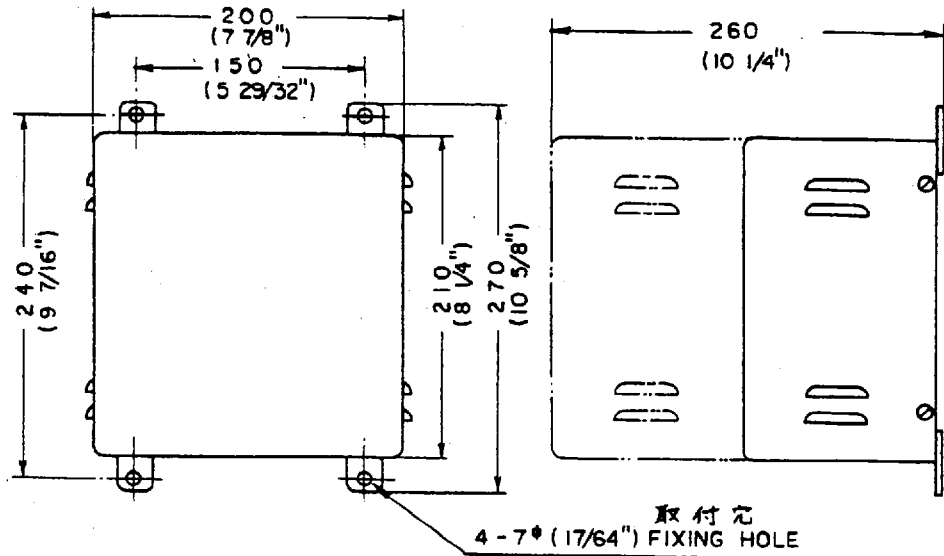

重量 WEIGHT: 12 kg (27 lbs)
単位 UNIT: mm (inches)

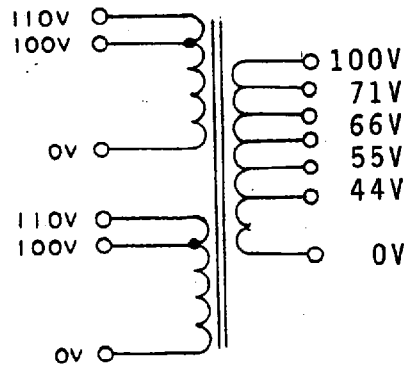

コンパス安全距離 COMPAS SAFE DISTANCE

スタンダード STANDARD	2.1 M
ステアリング STEERING	1.5 M

氷結防止 DE-ICER

品番 ITEM	品名 NAME	材質 MATERIAL	数量 Q'TY	図番 DWG.NO.	摘要 REMARKS
承認 APPROVED	三角法 THIRD ANGLE PROJECTION	名称 TITLE トランスユニット RU-3305 TRANSFORMER UNIT			
検図 CHECKED	尺度 SCALE	図番 DWG.NO. C3003-004-C			
製図 DRAWN	重量 WEIGHT	重量 12.2 kg			

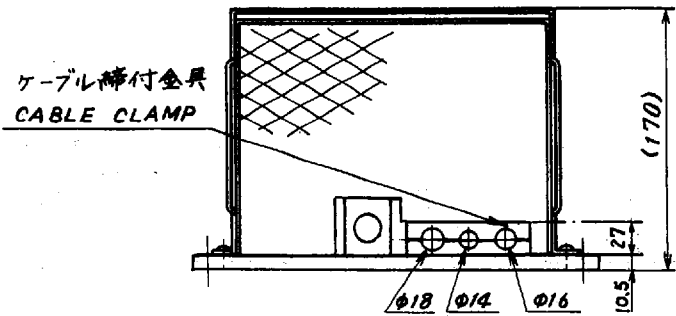
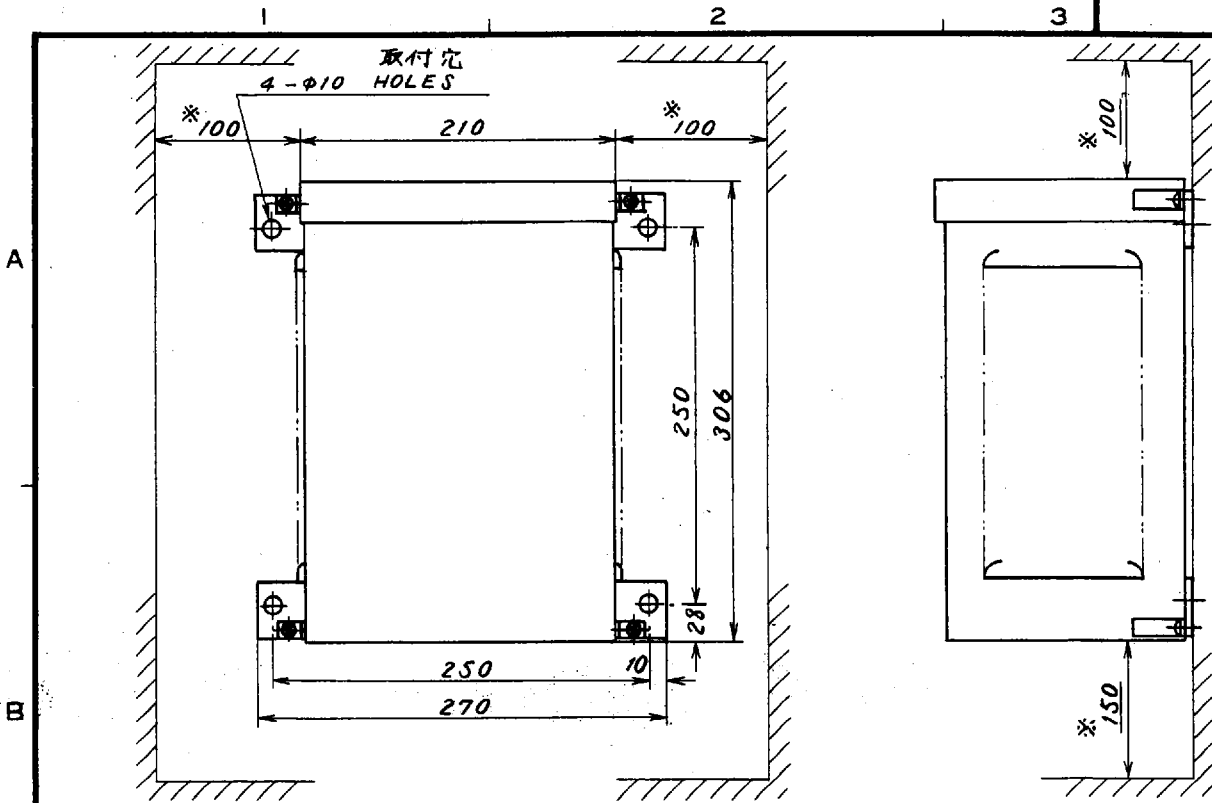

NOTE 1. *: 推奨サービス空間
RECOMMENDED SERVICING CLEARANCE.

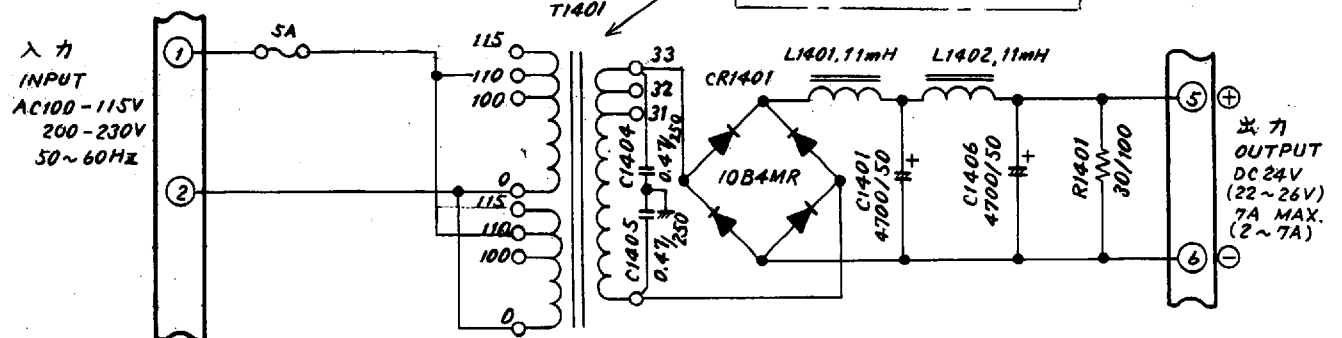
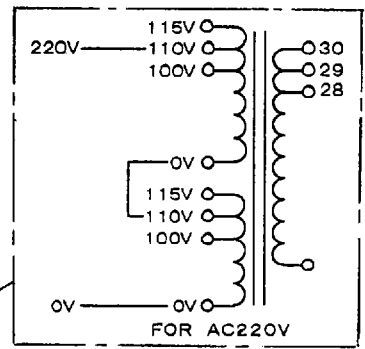

注 AC220V入力に対しては T1401 の一次巻線を直列に接続する。

NOTE FOR 220VAC INPUT, CONNECT T1401 PRIMARY WINDINGS IN SERIES.

DRAWN APR. 11 '97 T. YAMASAKI				TYPE RU-3423
CHECKED APR. 15 '97 K. KUSUNOKI				名称 整流器
APPROVED				外寸図
SCALE 1/5	MASS 16.5 kg	APPLICABLE TO; (MODEL)	BLOCK NO.	NAME RECTIFIER UNIT
DWG NO. C3002-005-K				OUTLINE DRAWING

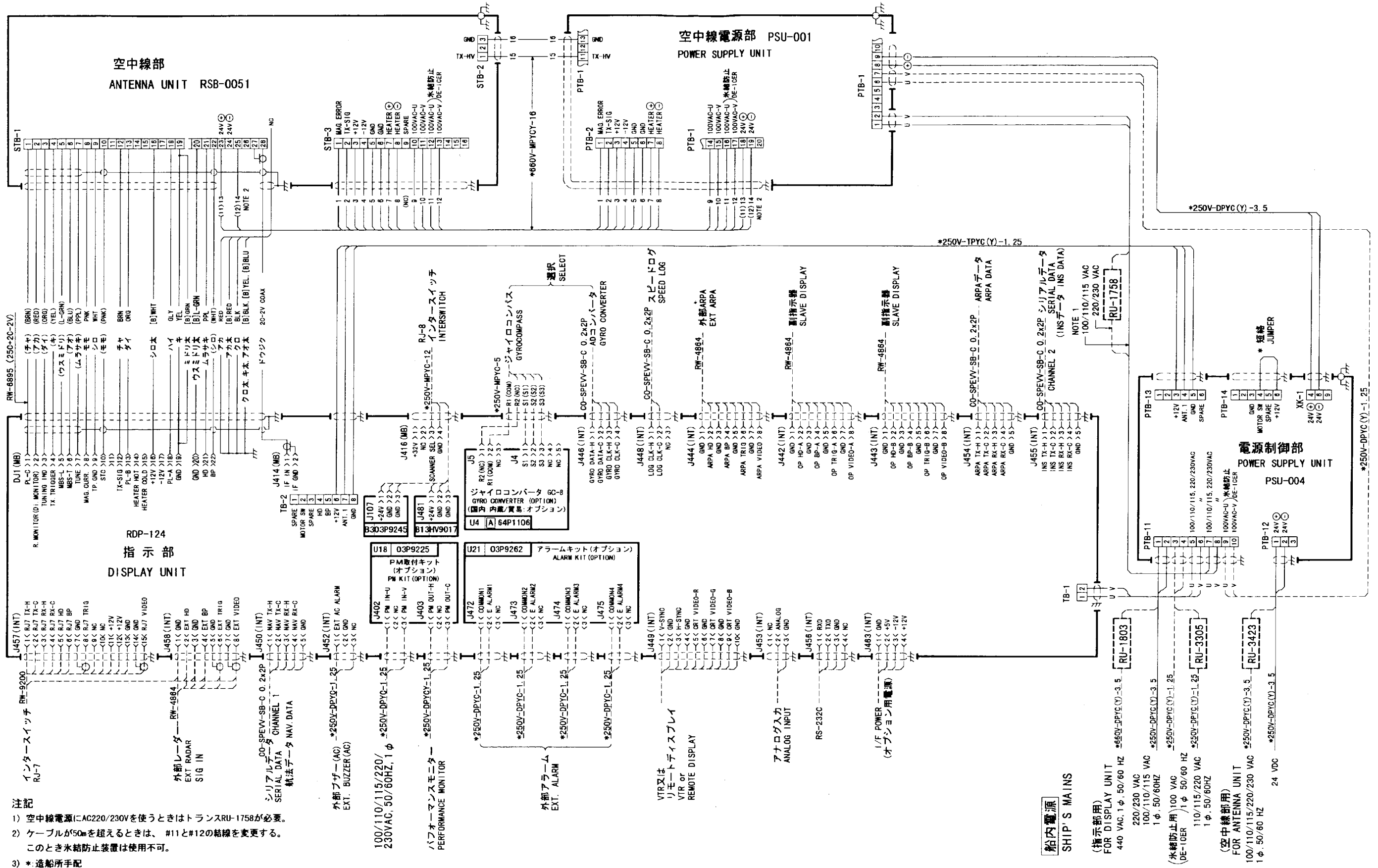

注記

- 空中線電源にAC220/230Vを使うときはトランスRU-1758が必要。
- ケーブルが50mを超えるときは、#11と#12の結線を変更する。
このとき氷結防止装置は使用不可。
- *:造船所手配
- () 内のカラーコードは内側シールド内の線を示す。

NOTE

- ANTENNA UNIT REQUIRES TRANSFORMER RU-1758 FOR 220/230 VAC SOURCE.
- CHANGE CONNECTION #11 AND #12 FOR USING CABLE 50 m OR MORE.
DE-ICER IS NO USE AFTER CONNECTION CHANGED.
- *: SHIPYARD SUPPLY
- WIRE COLOR CODE (): INSIDE WIRES. B-: BIG WIRES. L-: LIGHT COLOR.

DRAWN Sep 24 98 T. YAMASAKI		TYPE FR-2165DS
CHECKED Sep 24 98 K. Kusunoki		名 称 船舶用レーダー
APPROVED Sep 24 98 K. Kusunoki		図 名 相互結線図
SCALE MASS		名 称 MARINE RADAR
DWG. No. C3468-C01-C	03-144-6007-1	図 名 INTERCONNECTION DIAGRAM

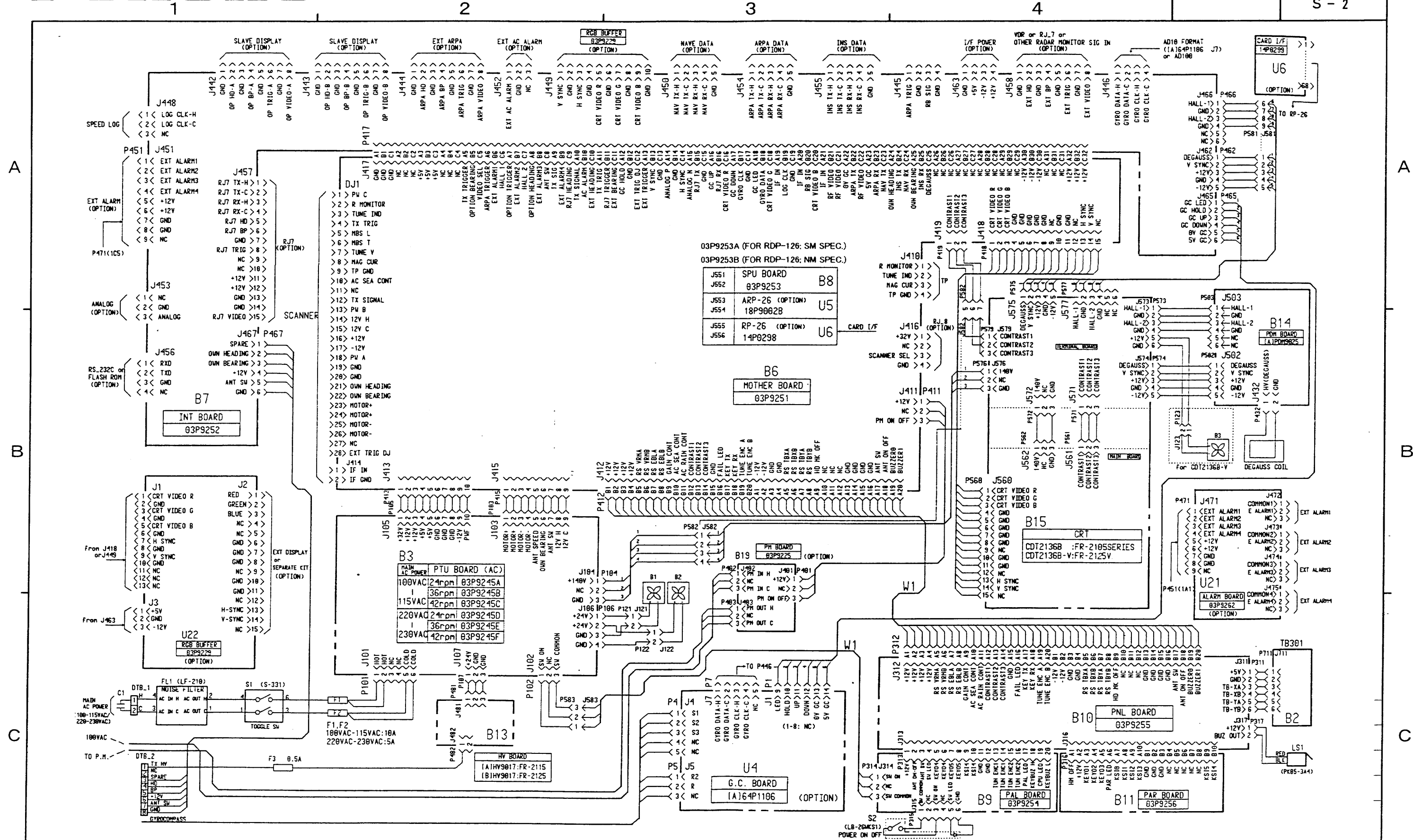

DRAW Apr 22 199 T. YAMASAKI CHECKED Apr 22 199 K. KUSUROKI APPROVED Apr 22 199 K. KUSUROKI SCALE / MASS kg DWG NO. C3464-K01-G	TYPE RDP-124/126 名称 指示部総合 (AC仕様) 回路図 NAME DISPLAY UNIT GENERAL (AC SOURCE) SCHEMATIC DIAGRAM
OTHERS FR-2125 FR-2115 APPLICABLE TO: (MODEL) BLOCK NO. 03-144-6008-10	NAME DISPLAY UNIT GENERAL (AC SOURCE) SCHEMATIC DIAGRAM

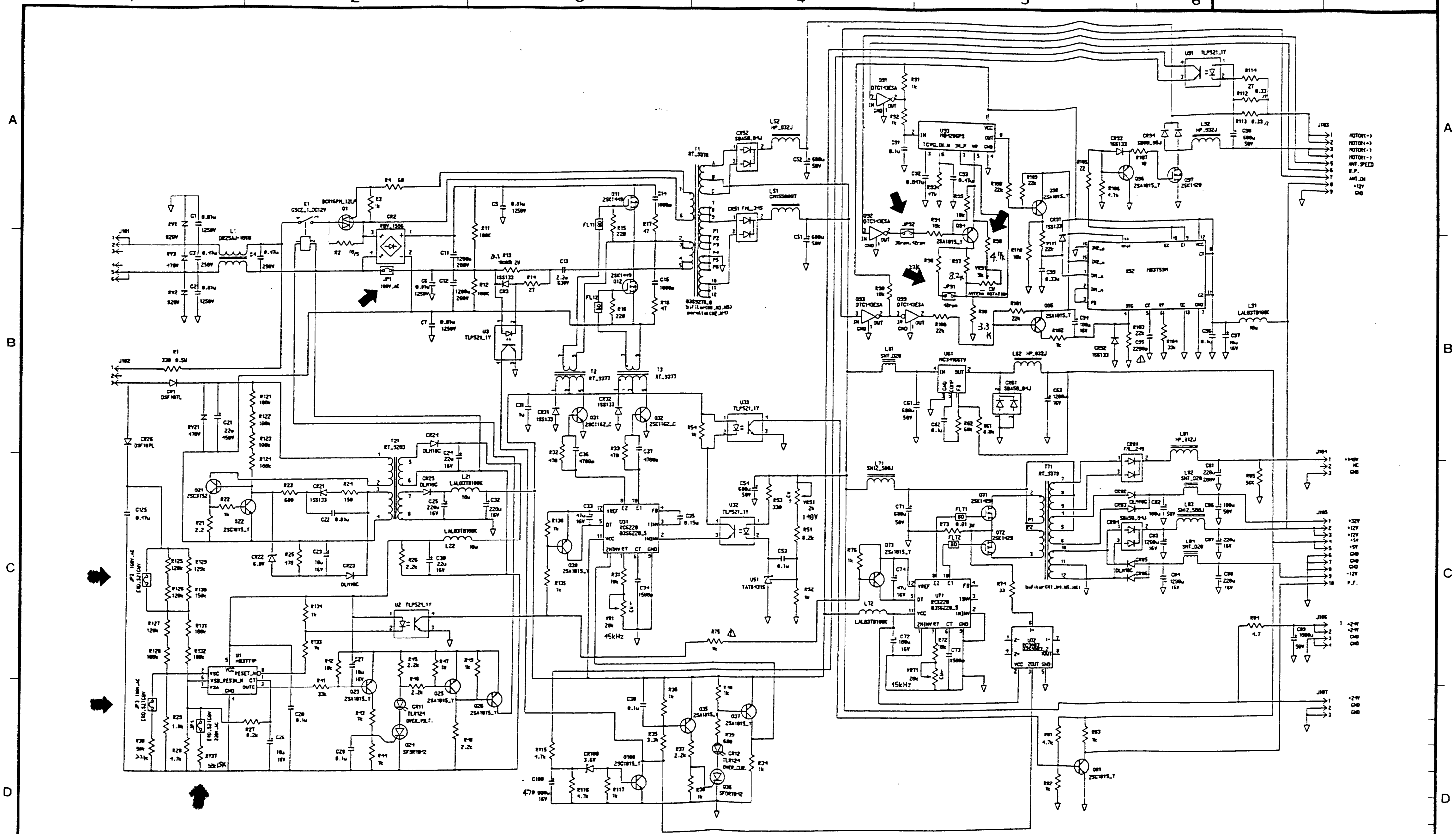

PWB	POWER	ANTENNA	JP1	JP2	JP3	JP4	JP91	JP92	R98
03P9245 A	100 VAC	24rpm	Short	Short	Short	Cut	Cut	Cut	4.7 k
03P9245 C	100 VAC	42rpm	Short	Short	Short	Cut	Cut	Short	1.2 k
03P9245 D	220 VAC	24rpm	Cut	Cut	Cut	Short	Cut	Cut	4.7 k
03P9245 F	220 VAC	42rpm	Cut	Cut	Cut	Short	Cut	Short	1.2 k

DRAWN Sep. 4 '99 E. Ichiyama		TYPE 03P9245
CHECKED Sep. 4 '99 K. Okamoto		名称 AC電源基板
APPROVED Sep. 9 '99 M. Yamamoto	FR-2125 FR-2115	回路図
SCALE MASS kg	APPLICABLE TO; (MODEL)	NAME PTU BOARD (AC)
DWG NO. C3464-K03-C	BLOCK NO. 03-144-6019-6	SCHMATIC DIAGRAM

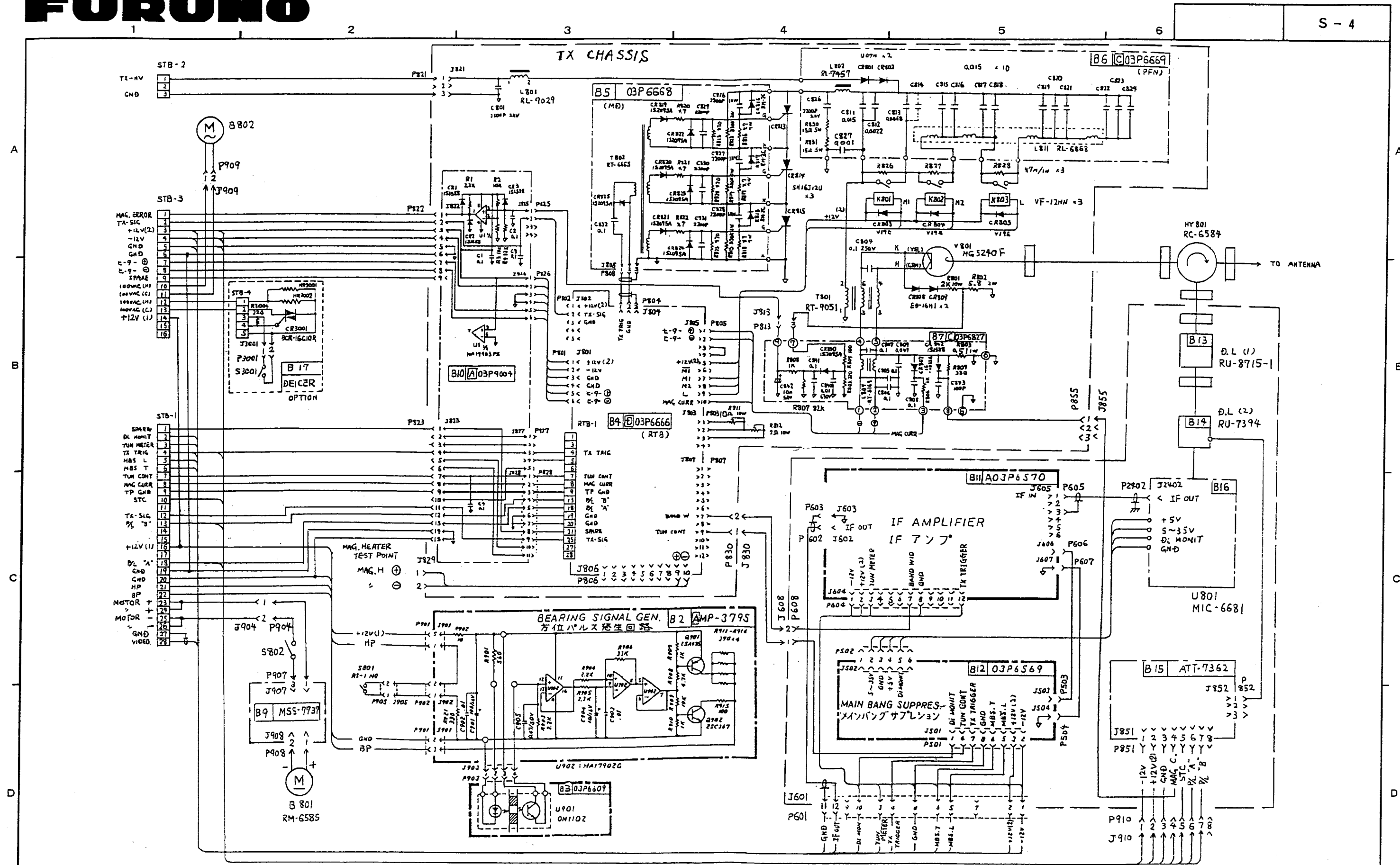

DRAWN Jun 22 '88 T. YAMASAKI	FR-1760DS	TYPE RSB-0051
CHECKED Jun 23 '88 K. Kusunoki	FR-2165DS	名称 空中線部総合
APPROVED Jun 23 '88 K. Kusunoki	FR-1460DS	回路図
SCALE MASS	FR-2160DS	NAME SCANNER UNIT GENERAL
DWG NO. C3357-K02-E	APPLICABLE TO; (MODEL)	BLOCK NO.
	03-107-6003-5	NAME SCHEMATIC DIAGRAM

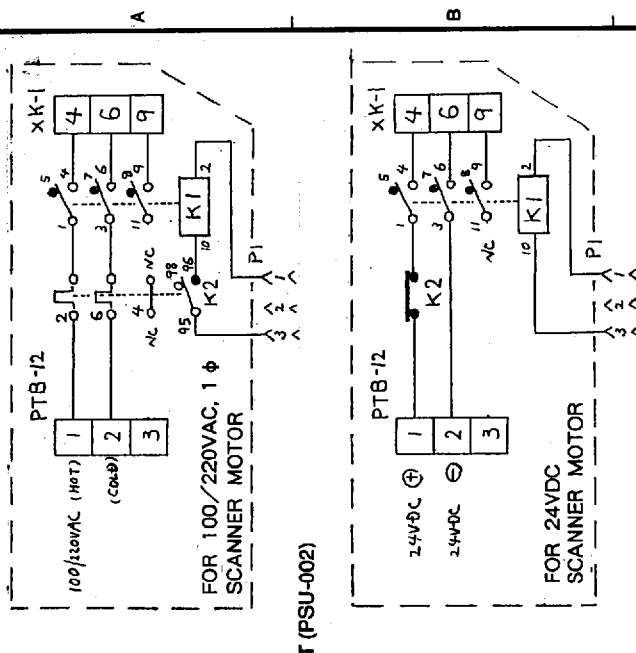
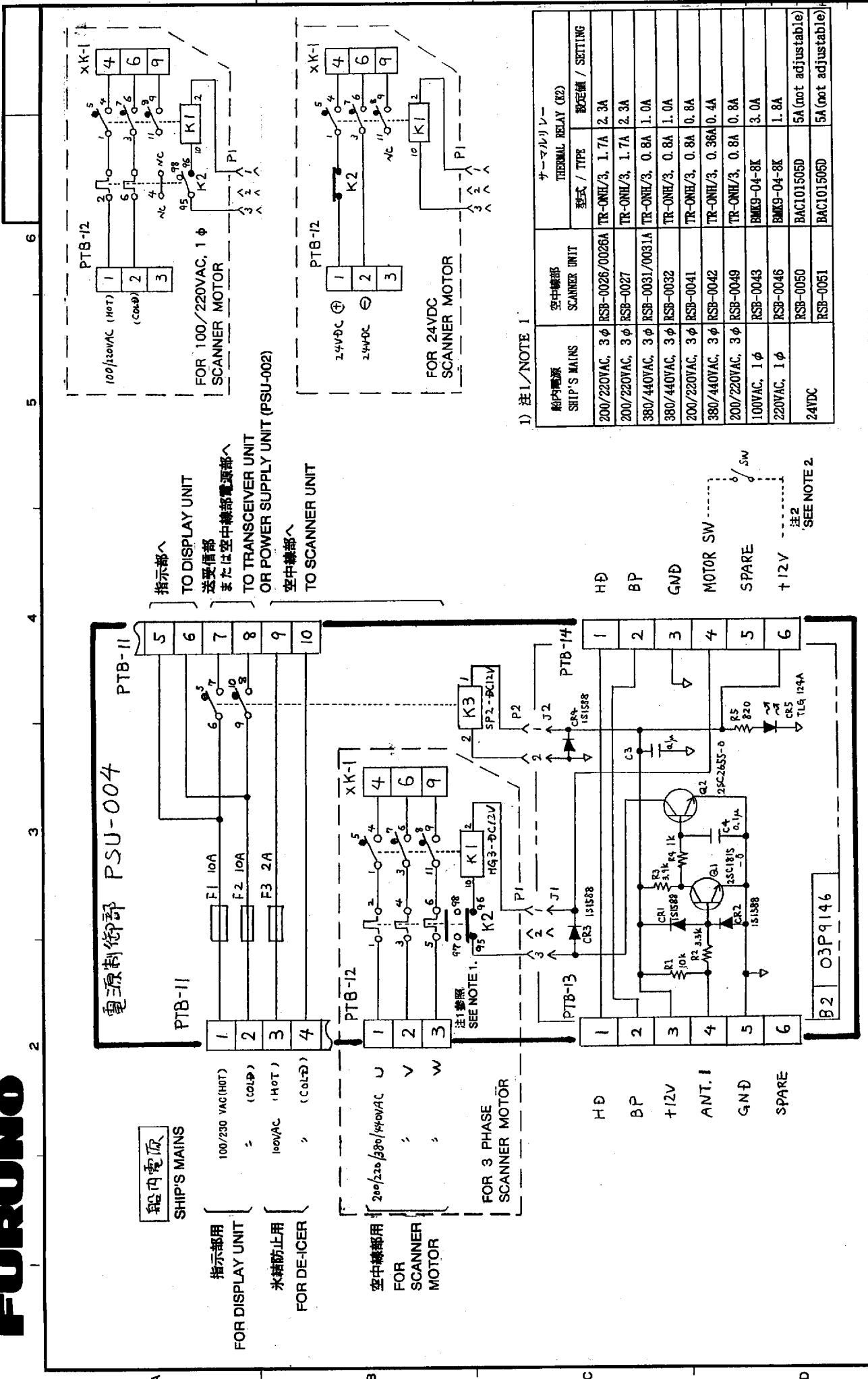

1) 注1/NOTE 1

船内電源 SHIP'S MAINS	空中線部 SCANNER UNIT	サーマルリレー THERMAL RELAY (K2)	
		型式 / TYPE	設定値 / SETTING
200/220VAC, 3φ	RSB-0026/0026A	TR-ONHL/3, 1.7A	2.3A
200/220VAC, 3φ	RSB-0027	TR-ONHL/3, 1.7A	2.3A
380/440VAC, 3φ	RSB-0031/0031A	TR-ONHL/3, 0.8A	1.0A
380/440VAC, 3φ	RSB-0032	TR-ONHL/3, 0.8A	1.0A
200/220VAC, 3φ	RSB-0041	TR-ONHL/3, 0.8A	0.8A
380/440VAC, 3φ	RSB-0042	TR-ONHL/3, 0.36A	0.4A
200/220VAC, 3φ	RSB-0049	TR-ONHL/3, 0.8A	0.8A
100VAC, 1φ	RSB-0043	BMEG-04-8K	3.0A
220VAC, 1φ	RSB-0046	BMEG-04-8K	1.8A
24VDC	RSB-0050	BAC101505D	5A (not adjustable)
	RSB-0051	BAC101505D	5A (not adjustable)

指示部へ
TO DISPLAY UNIT
送受信部
または空中線部電源部へ
TO TRANSMITTER UNIT
OR POWER SUPPLY UNIT (PSU-002)
空中線部へ
TO SCANNER UNIT

HΦ
BP
GND
MOTOR SW
SPARE
+12V
注2
SEE NOTE 2

DRWING	丸山 隆夫	TITLE	PSU-004
CHECKER	丸山 隆夫	名称	電源制御部
APPROVED	丸山 隆夫	回路図	回路図
SCALE	1/1	NAME	POWER SUPPLY UNIT
DWG. No.	C3385-K01-D		SCHEMATIC DIAGRAM

2) 注2/NOTE 2

FR-2160DS のときは PTB-14 の #4 と #6 を現地にて短絡すること

FOR FR-2160DS, PUT A JUMPER BETWEEN #4 AND #6 OF PTB-14 AT INSTALLATION.

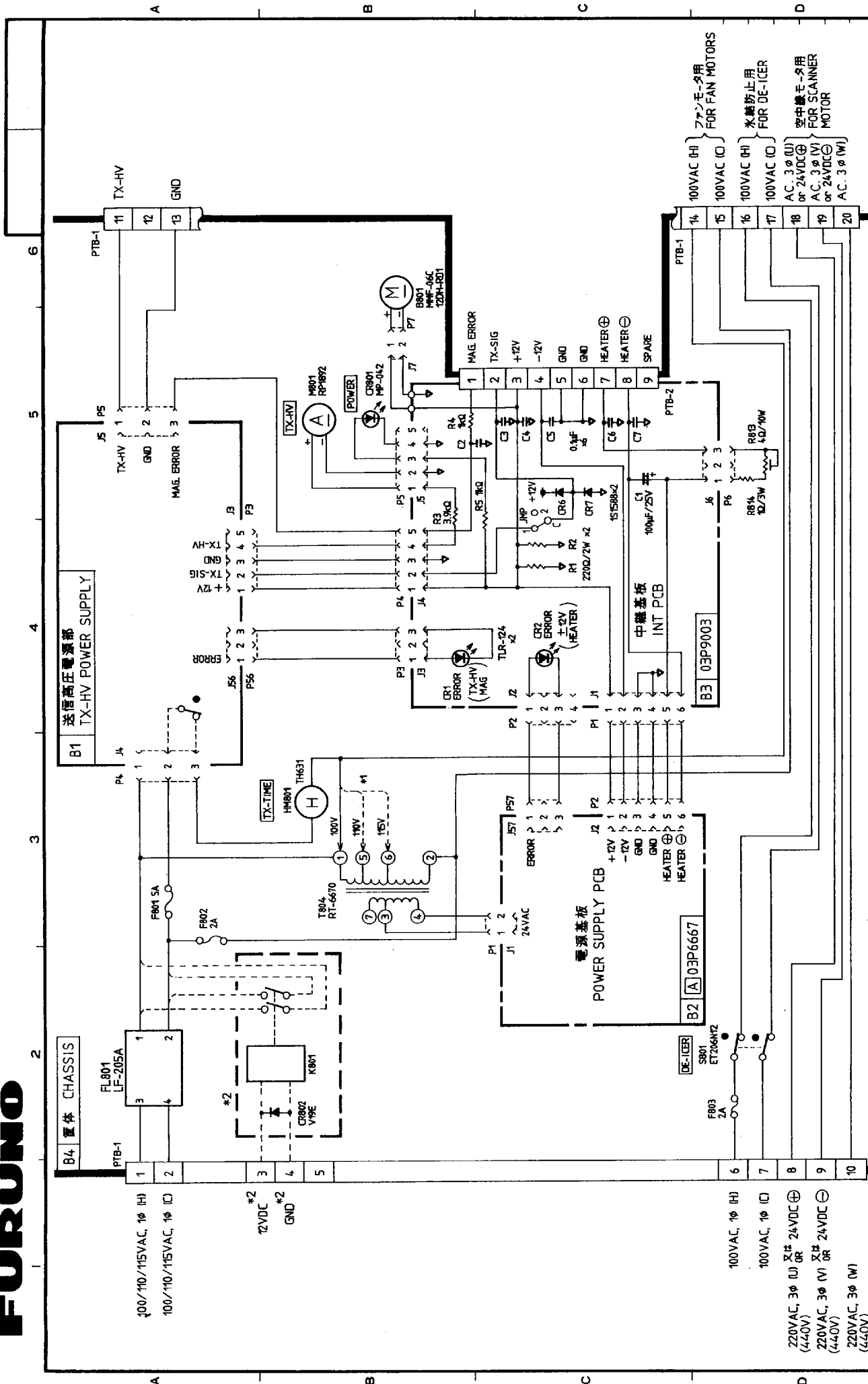

承認 APPROVED	APR. 25. '91 T. UAKAKO	名称 TITLE	PSU-001 空中線電源部 POWER SUPPLY UNIT
検閲 CHECKED	APR. 25. '91 I. ANAYASO	製図 DRAWN	HATAI
測図 DRAWN	35TH APR. '91	図番 DWG. NO.	C3353-K04-C

FR/FAP-2860S
FR/FAP-2852
FR-2050T

NOTE
*1. CHANGE CONNECTION FOR 110/115VAC SHIP'S MAINS.
*2. K801 IS NOT USED FOR STANDARD SET.

注
*1. 船内電源がAC110/115V時は、タップ変更必要。
*2. PSU-001標準品には、K801は使用しない。

100VAC, 1φ (H)
100VAC, 1φ (C)
220VAC, 3φ (U) 又は 24VDC ⊕ (440V)
220VAC, 3φ (V) 又は 24VDC ⊖ (440V)
220VAC, 3φ (W) (440V)